

# TR

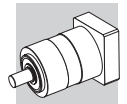

**BONFIGLIOLI**





# ZUSAMMENFASSUNG

Kapitel **Beschreibung**



<b>1</b>	<b>Allgemeine Informationen</b> .....	2
1.1	Symbole und Masseinheiten .....	2
1.2	Technische Merkmale Baureihe TR .....	3
1.3	Versionen .....	4
1.4	Bemessung des Getriebes .....	5
1.5	Berechnung der theoretischen Lebensdauer der Lager der Abtriebswelle .....	6
1.6	Bezeichnung .....	8
<b>2</b>	<b>Getriebe Auswahl Tabellen</b> .....	9
2.1	TR 053 .....	9
2.2	TR 060 .....	10
2.3	TR 080 .....	11
2.4	TR 105 .....	12
2.5	TR 130 .....	13
2.6	TR 160 .....	14
2.7	TR 190 .....	15
2.8	Axial- und Radialkraft Ausführung TR ... MB .....	16
2.9	Trägheitsmoment .....	17
2.9.1	TR 053 .....	17
2.9.2	TR 060 .....	18
2.9.3	TR 080 .....	19
2.9.4	TR 105 .....	20
2.9.5	TR 130 .....	21
2.9.6	TR 160 .....	22
2.9.7	TR 190 .....	23
<b>3</b>	<b>Abmessungen</b> .....	24
3.1	TR 053 .....	24
3.2	TR 060 .....	25
3.3	TR 080 .....	26
3.4	TR 105 .....	28
3.5	TR 130 .....	30
3.6	TR 160 .....	32
3.7	TR 190 .....	34
3.8	Getriebe ohne Motor-Verbindungsflansch .....	35

## Änderungen

Das Revisionsverzeichnis des Katalogs wird auf Seite 36 wiedergegeben.

Auf unserer Website [www.tecnoingranaggi.it](http://www.tecnoingranaggi.it) werden die Kataloge in ihrer letzten, überarbeiteten Version angeboten.

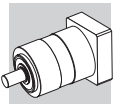

# 1 ALLGEMEINE INFORMATIONEN

## 1.1 SYMBOLE UND MASSEINHEITEN

$A_n$	[N]	Die <b>zulässige Axialkraft</b> ist die höchste axial einwirkende Kraft. Der gegebene Wert bezieht sich auf die Geschwindigkeit $n_2 = 100 \text{ min}^{-1}$
$C_t$	[Nm/arcmin]	<b>Verdrehssteifigkeit</b>
$i$	-	Das <b>Untersetzungsverhältnis</b> wird durch das Verhältnis zwischen der Geschwindigkeit der Antriebswelle und der Geschwindigkeit der Abtriebswelle des Getriebes ausgedrückt: $i = \frac{n_1}{n_2}$
$I$	-	Die <b>relative Einschaltdauer</b> wird als Verhältnis zwischen der Betriebszeit und der Zykluszeit definiert
$f_c$	-	<b>Benutzungsfaktor</b> . Korrekturfaktor, der bei der Bemessung des in Betriebsart S1 betriebenen Getriebes zum Tragen kommt.
$f_z$	-	<b>Betriebsfaktor</b>
$M_{a2}$	[Nm]	<b>Annehmbares höchstes Losbrechmoment</b> während des Arbeitszyklus mit $I < 60\%$
$M_{n2}$	[Nm]	<b>Übersetzbare Nenndrehmoment</b> , bezogen auf die Abtriebswelle des Getriebes
$M_{p2}$	[Nm]	<b>Not-Aus-Drehmoment</b> . Der Wert darf während der Lebensdauer des Getriebes nicht öfter als 1000 Mal angewandt, und nicht regelmäßig im Arbeitszyklus verwendet werden
$J$	[Kgcm <sup>2</sup> ]	<b>Trägheitsmoment</b> , bezogen auf die Antriebswelle
$L_{10}$	[h]	<b>Durchschnittliche Lebensdauer der Lager</b>
$n_1$	[min <sup>-1</sup> ]	<b>Eingangsnenngeschwindigkeit</b> (Dauerbetrieb S1). Dies ist der Bezugswert, der für Zyklen zu verwenden ist, die durch eine relative Einschaltdauer $I \geq 60\%$ und/oder Betrieb = 20 Min. gekennzeichnet sind
$n_{1max}$	[min <sup>-1</sup> ]	<b>Max. Momentangeschwindigkeit</b> . Diese kann gelegentlich und unter nicht häufig auftretenden Bedingungen erreicht werden. In aussetzendem Betrieb wie S5 kann sie andauernd nicht länger als 30 Sekunden angewandt werden
$R_n$	[N]	Die <b>zulässige Radialkraft</b> muss immer gleich oder größer der Soll-Radialkraft sein. Der Wert im Katalog bezieht sich auf die Wellenmitte und auf die Geschwindigkeit $n_2 = 100 \text{ min}^{-1}$
$T_c$	[°C]	<b>Gehäusetemperatur</b> . Diese darf unter keiner Betriebsbedingung 90°C überschreiten
$\varphi_s$	[arcmin]	Die <b>Berechnung des Standard-Winkelspiels</b> erfolgt unter statischen Bedingungen und mit Anwendung eines Drehmoments von 2% des Nenndrehmoments des Getriebes
$\varphi_R$	[arcmin]	Die <b>Berechnung des reduzierten Winkelspiels</b> erfolgt unter statischen Bedingungen und mit Anwendung eines Drehmoments von 2% des Nenndrehmoments des Getriebes
$\eta$	[%]	Der <b>dynamische Wirkungsgrad</b> wird durch das Verhältnis zwischen dem an der Abtriebswelle gemessenen Moment und dem unter Nennbedingungen an der Antriebswelle angewandten Moment berechnet: $\eta_d = \frac{M_2}{M_1 \times i} \times 100$
$Z$	-	<b>Anzahl</b> Beschleunigungen/Anläufe pro Stunde

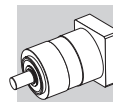

## 1.2 TECHNISCHE MERKMALE BAUREIHE TR

- Das begrenzte Winkelspiel, bis zu 5' bei der **Standard**-Ausführung, kann für Anwendungen die ein hohes Maß an Präzision und Wiederholgenauigkeit verlangen wahlweise auf 3' **verringert** werden.
- Die Lager sind für eine durchschnittliche Lebensdauer von 20.000 Stunden bei Nennbetriebsbedingungen ausgelegt. Standardausstattung mit starren Kugellagern für die Baugrößen 053, 060. Kegelrollenlager für die Baugrößen 080, 105, 130, 160 und 190.
- Das Getriebe wird werkseitig mit geeignetem Schmiermittel für Umgebungstemperaturen zwischen 0°...40°C befüllt. Die Schmiermittelmenge ist hierbei von der Einbaulage abhängig, die demnach bei der Bestellung angegeben werden muss. Wenn keine Verunreinigung von außen vorliegt, braucht das Schmiermittel nicht regelmäßig gewechselt zu werden. Der verwendete Schmiermitteltyp, Fett oder Synthetiköl, und das Material der Dichtungen richten sich nach der Betriebsart und der Größe des Getriebes. In der nachstehenden Tabelle sind die verschiedenen möglichen Kombinationen aufgeführt:

duty	053	060	080	105	130	160	190
S1	G / V	G / V	O / V	O / V	O / V	O / V	O / V
S5	G / NBR	G / NBR	G / NBR	G / NBR	G / NBR	G / NBR	G / NBR

Legende:

S1 = Dauerbetrieb

O = Synthetiköl mit Viskosität ISO VG 220

V = Dichtungen aus Viton®

S5 = Aussetzender Betrieb

G = Fett mit Konsistenzgrad 00

NBR = Dichtungen aus Nitrilgummi

- Schutzgrad IP65
- Max. Geräuschemission  $L_p \leq 70$  dB(A) -  $n_1 = 3000$  min<sup>-1</sup>
- Weitreichende Konfigurationsmöglichkeit auf der Seite der Motorkupplung
- Einstufige Ausführungen sind bis zu einem Verhältnis von  $i = 10$  ( $i = 9$  für Baugröße 053) lieferbar

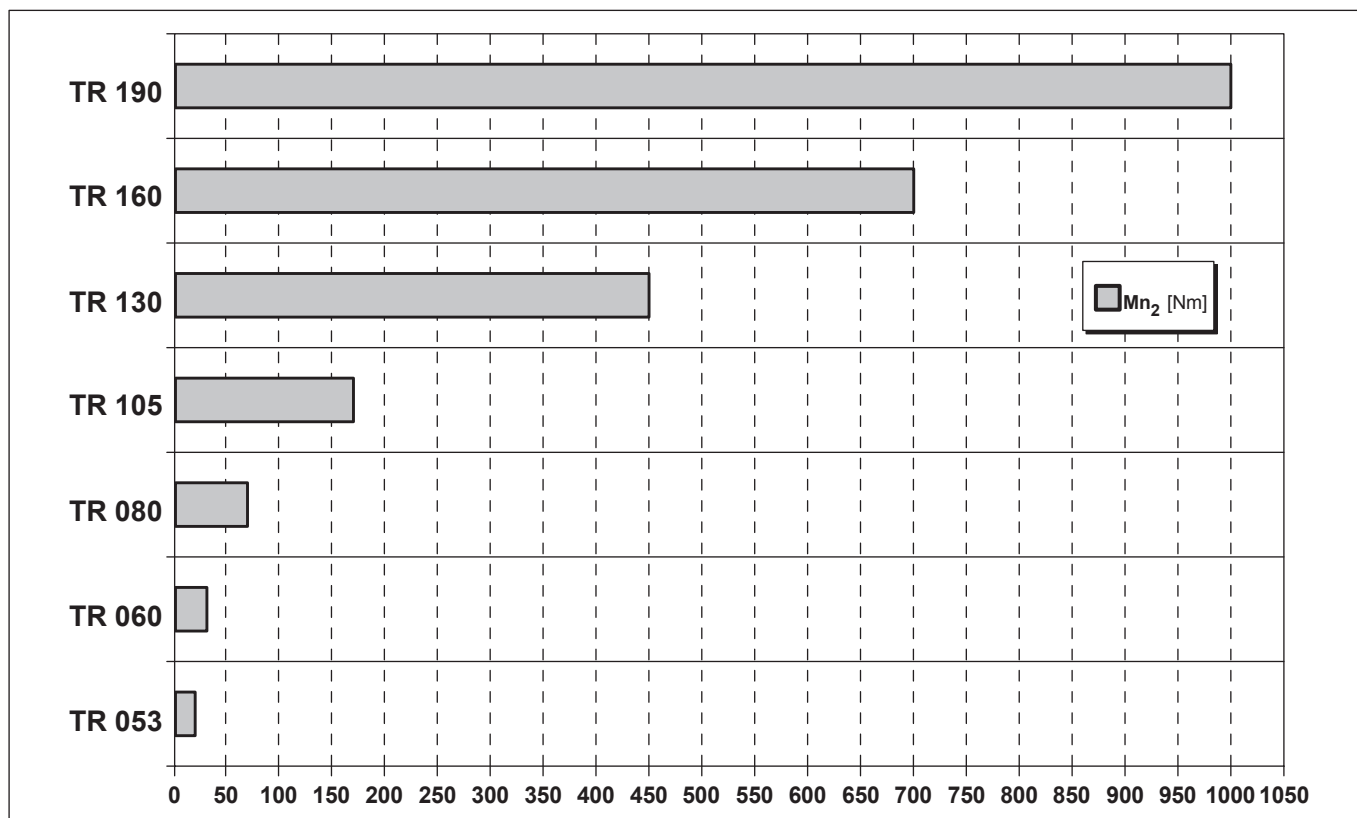

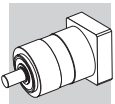

### 1.3 VERSIONEN

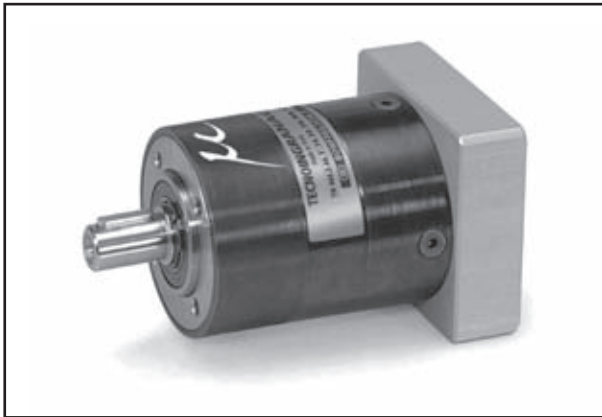

—

**Stirradgetriebe**

053...190



IS

**Getriebemotor mit  
zylindrischer  
Antriebswelle**

053...160

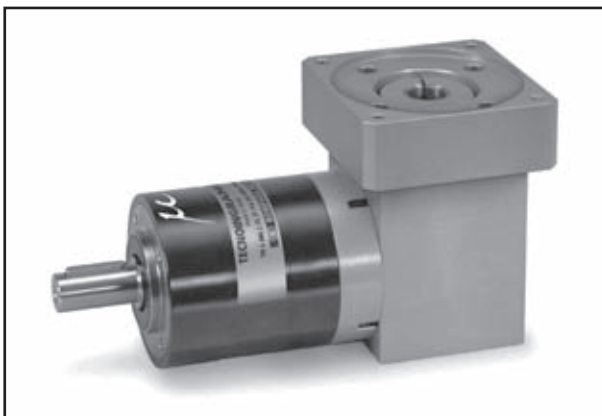

G

**Winkelgetriebe**

053...160

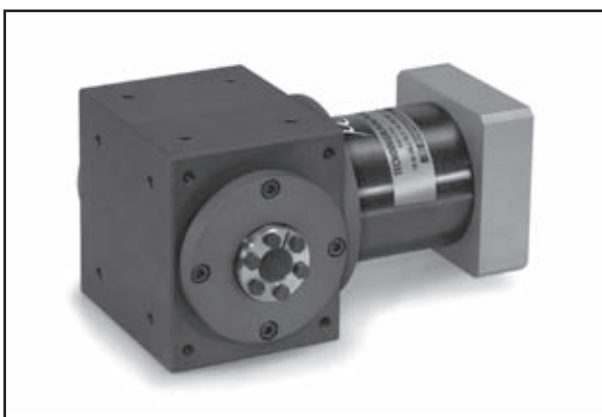

MB

**Winkelgetriebe mit  
durchgehender  
Hohlwelle**

080...160

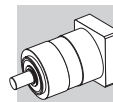

## 1.4 BEMESSUNG DES GETRIEBES

- Die relative Einschaltdauer I ermitteln:

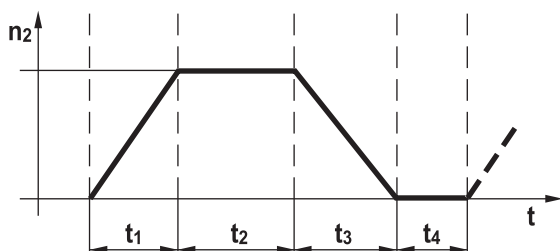

$$I [\%] = \frac{t_1 + t_2 + t_3}{t_1 + t_2 + t_3 + t_4}$$

- $t_1$  = Beschleunigungszeit
- $t_2$  = Betriebsdauer bei konstanter Geschwindigkeit
- $t_3$  = Auslaufzeit
- $t_4$  = Pausenzeit

- Die der Applikation entsprechende Betriebsart feststellen:

	Z ≤ 1000	Z > 1000
I < 60%	S5	S1
I ≥ 60%	S1	S1

### S5 Aussetzender Betrieb

- Das Getriebe suchen, bei dem die Bedingung getestet ist:

$$M_{a2} \geq M_{1max} \times i \times \eta$$

$M_{1max}$  = Max. Beschleunigungsmoment des Motors

### S1 Dauerbetrieb

- Den Betriebsfaktor  $f_z$  ermitteln:

Z	$f_z$
Z ≤ 1000	1.00
1000 < Z ≤ 1500	1.25
1500 < Z ≤ 2000	1.50
2000 < Z ≤ 2500	1.75
2500 < Z ≤ 3000	2.00
Z > 3000	Anrufen

- Den Benutzungsfaktor  $f_c$  ermitteln:

	20%...60%	80%	100%
	1.0	1.2	1.4

- Das Getriebe suchen, bei dem die Bedingung getestet ist:

$$M_{n2} \geq M_{1max} \times i \times \eta \times f_z \times f_c$$



Wenn aufgrund der Einsatzbedingungen des Getriebes eine höhere Betriebstemperatur als normal zu erwarten ist, sollten im Auftrag Dichtungen mit Mischung aus Viton® angegeben und die Option **S1** gewählt werden. Die für das Getriebe zulässige Höchstgeschwindigkeit [ $n_{1max}$ ] sollte auf keinen Fall überschritten werden. Wenn am Gehäuse Temperaturen über 90 °C festgestellt werden, sollte die Betriebsgeschwindigkeit reduziert oder ein zusätzliches Kühlsystem angebracht werden.

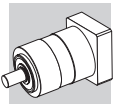

## 1.5 BERECHNUNG DER THEORETISCHEN LEBENSDAUER DER LAGER DER ABTRIEBSWELLE

Für starre Kugellager (CS) oder Kegelrollenlager (CR) kann die theoretische Lebensdauer in Stunden mit Hilfe der Formeln, die die tatsächlich angewandten Radial- und Axialkräfte berücksichtigen, berechnet werden.

TR 053	TR 060	TR 080	TR 105	TR 130	TR 160	TR 190
CS	CS	CR	CR	CR	CR	CR

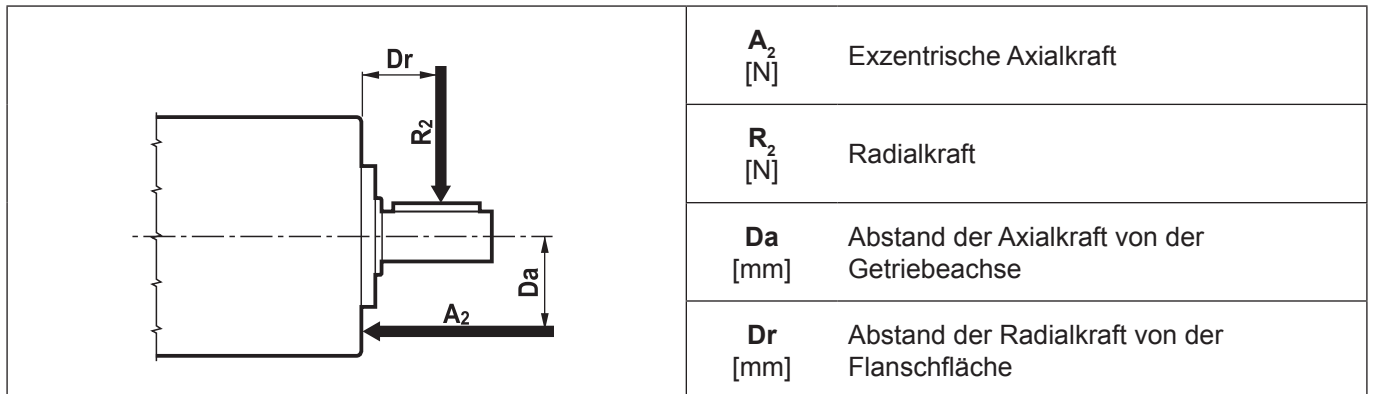

### BERECHNUNG DER THEORETISCHEN LEBENSDAUER DER STARREN KUGELLAGER (CS)

$$F_{eq} = \frac{A_2 \times D_a + R_2 \times (D_r + b)}{a}$$

$$n_a = \frac{n_1 \times t_1 + n_2 \times t_2 + \dots + n_5 \times t_5}{t_1 + t_2 + t_3 + t_4 + t_5 + t_6}$$

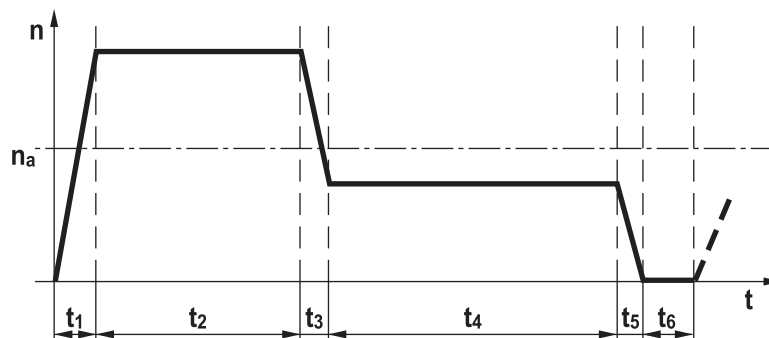

$$L_{10}(h) = \frac{16666}{n_a} \times \left( \frac{c}{F_{eq}} \right)^3$$

Getriebekonstanten	TR 053	TR 060
a	15.5	14.4
b	17	17.4
c	5600	9550

$F_{eq}$  [N] = Äquivalente Kraft, die sich aus der Wirkung der gleichzeitig einwirkenden Radial- und Axialkräfte ergibt

$n_a$  [min<sup>-1</sup>] = Durchschnittliche Geschwindigkeit der Abtriebswelle

$L_{10}(h)$  = Theoretische Lebensdauer der Lager

Den Parameter  $e = A_2/F_{eq}$  berechnen und prüfen, ob die Bedingung  $e \leq 0.19$  eingetreten ist. Im Fall  $e > 0.19$  wenden Sie sich bitte an unseren Technischen Kundendienst.

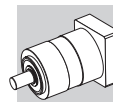

**BERECHNUNG DER THEORETISCHEN LEBENSDAUER DER KEGELROLLENLAGER (CR)**

$$F_{eq} = \frac{A_2 \times D_a + R_2 \times (D_r + b)}{a}$$

$$n_a = \frac{n_1 \times t_1 + n_2 \times t_2 + \dots + n_5 \times t_5}{t_1 + t_2 + t_3 + t_4 + t_5 + t_6}$$

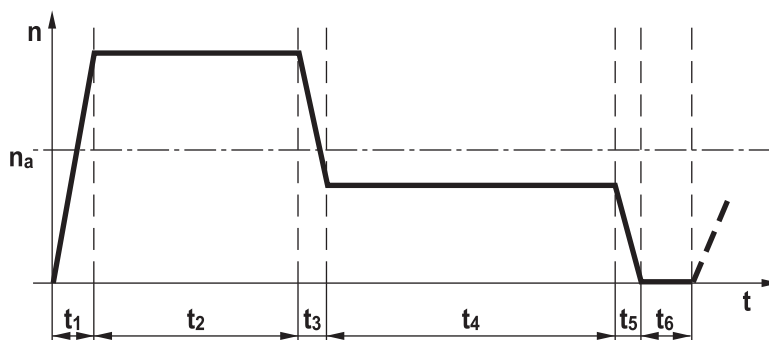

$$L_{10}(h) = \frac{16666}{n_a} \times \left( \frac{c}{F_{eq}} \right)^{10/3}$$

Getriebekonstanten	TR 080	TR 105	TR 130	TR 160	TR 190
<b>a</b>	28	35	45	52	62
<b>b</b>	35.55	41.25	51.75	56.75	64.25
<b>c</b>	30800	51200	76500	99000	14000

$F_{eq}$  [N] = Äquivalente Kraft, die sich aus der Wirkung der gleichzeitig einwirkenden Radial- und Axialkräfte ergibt  
 $n_a$  [min<sup>-1</sup>] = Durchschnittliche Geschwindigkeit der Abtriebswelle  
 $L_{10}(h)$  = Theoretische Lebensdauer der Lager

Den Parameter  $e = A_2/F_{eq}$  berechnen und prüfen, ob die Bedingung  $e \leq 0.4$  eingetreten ist. Im Fall  $e > 0.4$  wenden Sie sich bitte an unseren Technischen Kundendienst.

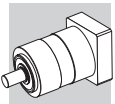

## 1.6 BEZEICHNUNG

TR G 080 2 70 10' 14 30 60 75 S1 O TH

—  
TH: MOTOR MIT GEWINDEBOHRUNGEN

EINBAULAGE:  
O (horizontal)  
VS (vertikal - Motor oben)  
VI (vertikal - Motor unten)

—  
S1: Konfiguration für Dauerbetrieb

ABSTAND DER BOHRUNGEN AM MOTORFLANSCH

ZENTRIERUNGSDURCHMESSER MOTORFLANSCH

LÄNGE ANTRIEBSWELLE

DURCHMESSER ANTRIEBSWELLE

	TR 053	TR 060	TR 080	TR 105	TR 130	TR 160	TR 190
D	6 - 6.35	6 - 6.35	8 - 9	11 - 12	14 - 15.875	14 - 15.875	14 - 16
	7 - 8	7 - 8	9.52 - 11	12.7 - 14	16 - 19	16 - 19	19 - 22
	9 - 9.52	9 - 9.52	12 - 12.7	15 - 15.875	22 - 24	22 - 24	24 - 28
	10 - 11	10 - 11	14 - 15.875	16 - 19	28 - 32	28 - 32	32 - 35
	12 - 12.7	12 - 12.7	16 - 17	22 - 24	35 - 38	35 - 38	38 - 42
	14	14	19 - 19.05	28 - 32			45 - 48

WINKELSPIEL

	1 Stufe	2 Stufen	3 Stufen
Standard (TR053...TR190)	5'	5'	7'
Reduziert (TR060...TR190)	3'	3'	5'

UNTERSETZUNGSVERHÄLTNIS

UNTERSETZUNGSSTUFEN  
1, 2, 3

BAUGRÖSSE

VERSIONEN  
— = Stirnradgetriebe  
IS = Getriebe mit zylindrischer Antriebswelle  
G = Stirnkegelradgetriebe  
MB = Stirnkegelradgetriebe mit durchgehender hohler Abtriebswelle

BAUREIHE  
TR

Optionale Variante

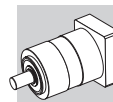

## 2 GETRIEBE AUSWAHLTABELLEN

### 2.1 TR 053

TR 053												
i	M <sub>n2</sub> [Nm]	M <sub>a2</sub> [Nm]	M <sub>p2</sub> [Nm]	n <sub>1</sub> [min <sup>-1</sup> ]	n <sub>1max</sub> [min <sup>-1</sup> ]	φ <sub>S</sub> [arcmin]	φ <sub>R</sub> [arcmin]	C <sub>t</sub> [Nm/arcmin]	R <sub>n1</sub> [N]	R <sub>n2</sub> [N]	A <sub>n2</sub> [N]	η %
TR 053 1_3	12	22	40	3300	4000	5'	-	1	200	500	600	97
TR 053 1_4	15	28	45	3500	5000	5'	-	1	200	500	600	97
TR 053 1_5	15	28	45	3500	5000	5'	-	1	200	500	600	97
TR 053 1_6	15	28	45	3500	5000	5'	-	1	200	500	600	97
TR 053 1_7	15	28	45	4000	6000	5'	-	1	200	500	600	97
TR 053 1_9	12	22	40	4000	6000	5'	-	1	200	500	600	97
TR 053 2_12	20	30	60	3300	4000	5'	-	0.9	200	500	600	94
TR 053 2_15	20	30	60	3300	4000	5'	-	0.9	200	500	600	94
TR 053 2_16	20	30	60	3500	5000	5'	-	0.9	200	500	600	94
TR 053 2_20	20	30	60	3500	5000	5'	-	0.9	200	500	600	94
TR 053 2_25	20	30	60	3500	5000	5'	-	0.9	200	500	600	94
TR 053 2_28	20	30	60	4000	6000	5'	-	0.9	200	500	600	94
TR 053 2_35	20	30	60	4000	6000	5'	-	0.9	200	500	600	94
TR 053 2_36	15	28	45	4000	6000	5'	-	0.9	200	500	600	94
TR 053 2_45	20	30	60	4000	6000	5'	-	0.9	200	500	600	94
TR 053 3_60	20	30	60	3500	5000	7'	-	0.7	200	500	600	90
TR 053 2_81	12	22	40	4000	6000	5'	-	0.9	200	500	600	94
TR 053 3_48	20	30	60	3500	5000	7'	-	0.7	200	500	600	90
TR 053 3_64	20	30	60	3500	5000	7'	-	0.7	200	500	600	90
TR 053 3_75	20	30	60	3500	5000	7'	-	0.7	200	500	600	90
TR 053 3_80	20	30	60	3500	5000	7'	-	0.7	200	500	600	90
TR 053 3_84	20	30	60	4000	6000	7'	-	0.7	200	500	600	90
TR 053 3_100	20	30	60	3500	5000	7'	-	0.7	200	500	600	90
TR 053 3_112	20	30	60	4000	6000	7'	-	0.7	200	500	600	90
TR 053 3_125	20	30	60	3500	5000	7'	-	0.7	200	500	600	90
TR 053 3_140	20	30	60	4000	6000	7'	-	0.7	200	500	600	90
TR 053 3_144	20	30	60	4000	6000	7'	-	0.7	200	500	600	90
TR 053 3_175	20	30	60	4000	6000	7'	-	0.7	200	500	600	90
TR 053 3_180	20	30	60	4000	6000	7'	-	0.7	200	500	600	90
TR 053 3_216	20	30	60	3500	5000	7'	-	0.7	200	500	600	90
TR 053 3_225	20	30	60	4000	6000	7'	-	0.7	200	500	600	90
TR 053 3_245	20	30	60	4000	6000	7'	-	0.7	200	500	600	90
TR 053 3_252	20	30	60	4000	6000	7'	-	0.7	200	500	600	90
TR 053 3_324	20	30	60	4000	6000	7'	-	0.7	200	500	600	90
TR 053 3_405	20	30	60	4000	6000	7'	-	0.7	200	500	600	90
TR 053 3_567	20	30	60	4000	6000	7'	-	0.7	200	500	600	90
TR 053 3_729	12	22	40	4000	6000	7'	-	0.7	200	500	600	90

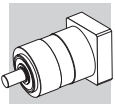

## 2.2 TR 060

TR 060												
i	M <sub>n2</sub> [Nm]	M <sub>a2</sub> [Nm]	M <sub>p2</sub> [Nm]	n <sub>1</sub> [min <sup>-1</sup> ]	n <sub>1max</sub> [min <sup>-1</sup> ]	φ <sub>S</sub> [arcmin]	φ <sub>R</sub> [arcmin]	C <sub>t</sub> [Nm/arcmin]	R <sub>n1</sub> [N]	R <sub>n2</sub> [N]	A <sub>n2</sub> [N]	η %
TR 060 1_3	18	35	70	3300	4000	5'	3'	3.0	200	600	700	97
TR 060 1_4	25	40	90	3500	5000	5'	3'	3.0	200	600	700	97
TR 060 1_5	25	40	90	3500	5000	5'	3'	3.0	200	600	700	97
TR 060 1_6	25	40	90	3500	5000	5'	3'	3.0	200	600	700	97
TR 060 1_7	25	40	90	4000	6000	5'	3'	3.0	200	600	700	97
TR 060 1_10	18	35	70	4000	6000	5'	3'	3.0	200	600	700	97
TR 060 2_9	18	35	70	3300	4000	5'	3'	2.5	200	600	700	94
TR 060 2_12	30	45	100	3300	4000	5'	3'	2.5	200	600	700	94
TR 060 2_15	30	45	100	3300	4000	5'	3'	2.5	200	600	700	94
TR 060 2_16	30	45	100	3500	5000	5'	3'	2.5	200	600	700	94
TR 060 2_20	30	45	100	3500	5000	5'	3'	2.5	200	600	700	94
TR 060 2_25	30	45	100	3500	5000	5'	3'	2.5	200	600	700	94
TR 060 2_28	30	45	100	4000	6000	5'	3'	2.5	200	600	700	94
TR 060 2_30	18	35	70	4000	6000	5'	3'	2.5	200	600	700	94
TR 060 2_35	30	45	100	4000	6000	5'	3'	2.5	200	600	700	94
TR 060 2_36	25	40	90	3500	5000	5'	3'	2.5	200	600	700	94
TR 060 2_40	30	45	100	4000	6000	5'	3'	2.5	200	600	700	94
TR 060 2_50	30	45	100	4000	6000	5'	3'	2.5	200	600	700	94
TR 060 2_70	30	45	100	4000	6000	5'	3'	2.5	200	600	700	94
TR 060 2_100	18	35	70	4000	6000	5'	3'	2.5	200	600	700	94
TR 060 3_48	30	45	100	3500	5000	7'	5'	2.0	200	600	700	90
TR 060 3_64	30	45	100	3500	5000	7'	5'	2.0	200	600	700	90
TR 060 3_75	30	45	100	3500	5000	7'	5'	2.0	200	600	700	90
TR 060 3_80	30	45	100	3500	5000	7'	5'	2.0	200	600	700	90
TR 060 3_84	30	45	100	4000	6000	7'	5'	2.0	200	600	700	90
TR 060 3_90	18	35	70	4000	6000	7'	5'	2.0	200	600	700	90
TR 060 3_120	30	45	100	4000	6000	7'	5'	2.0	200	600	700	90
TR 060 3_125	30	45	100	3500	5000	7'	5'	2.0	200	600	700	90
TR 060 3_140	30	45	100	4000	6000	7'	5'	2.0	200	600	700	90
TR 060 3_150	30	45	100	4000	6000	7'	5'	2.0	200	600	700	90
TR 060 3_160	30	45	100	4000	6000	7'	5'	2.0	200	600	700	90
TR 060 3_175	30	45	100	4000	6000	7'	5'	2.0	200	600	700	90
TR 060 3_200	30	45	100	4000	6000	7'	5'	2.0	200	600	700	90
TR 060 3_210	30	45	100	4000	6000	7'	5'	2.0	200	600	700	90
TR 060 3_216	30	45	100	3500	5000	7'	5'	2.0	200	600	700	90
TR 060 3_250	30	45	100	4000	6000	7'	5'	2.0	200	600	700	90
TR 060 3_280	30	45	100	4000	6000	7'	5'	2.0	200	600	700	90
TR 060 3_350	30	45	100	4000	6000	7'	5'	2.0	200	600	700	90
TR 060 3_400	30	45	100	4000	6000	7'	5'	2.0	200	600	700	90
TR 060 3_500	30	45	100	4000	6000	7'	5'	2.0	200	600	700	90
TR 060 3_700	30	45	100	4000	6000	7'	5'	2.0	200	600	700	90
TR 060 3_1000	18	35	70	4000	6000	7'	5'	2.0	200	600	700	90

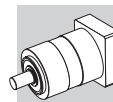

## 2.3 TR 080

TR 080												
i	M <sub>n2</sub> [Nm]	M <sub>a2</sub> [Nm]	M <sub>p2</sub> [Nm]	n <sub>1</sub> [min <sup>-1</sup> ]	n <sub>1max</sub> [min <sup>-1</sup> ]	φ <sub>S</sub> [arcmin]	φ <sub>R</sub> [arcmin]	C <sub>t</sub> [Nm/arcmin]	R <sub>n1</sub> [N]	R <sub>n2</sub> [N]	A <sub>n2</sub> [N]	η %
TR 080 1_3	40	80	180	2900	3500	5'	3'	8.0	400	2500	3000	97
TR 080 1_4	50	80	200	3100	4500	5'	3'	8.0	400	2500	3000	97
TR 080 1_5	50	80	200	3200	4500	5'	3'	8.0	400	2500	3000	97
TR 080 1_6	50	80	200	3200	4500	5'	3'	8.0	400	2500	3000	97
TR 080 1_7	50	80	200	4000	6000	5'	3'	8.0	400	2500	3000	97
TR 080 1_10	40	80	180	4000	6000	5'	3'	8.0	400	2500	3000	97
TR 080 2_9	40	80	180	2900	3500	5'	3'	6.5	400	2500	3000	94
TR 080 2_12	70	100	250	2900	3500	5'	3'	6.5	400	2500	3000	94
TR 080 2_15	70	100	250	2900	3500	5'	3'	6.5	400	2500	3000	94
TR 080 2_16	70	100	250	3100	4500	5'	3'	6.5	400	2500	3000	94
TR 080 2_20	70	100	250	3200	4500	5'	3'	6.5	400	2500	3000	94
TR 080 2_25	70	100	250	3200	4500	5'	3'	6.5	400	2500	3000	94
TR 080 2_28	70	100	250	4000	6000	5'	3'	6.5	400	2500	3000	94
TR 080 2_30	40	80	180	4000	6000	5'	3'	6.5	400	2500	3000	94
TR 080 2_35	70	100	250	4000	6000	5'	3'	6.5	400	2500	3000	94
TR 080 2_36	50	80	200	3200	4500	5'	3'	6.5	400	2500	3000	94
TR 080 2_40	70	100	250	4000	6000	5'	3'	6.5	400	2500	3000	94
TR 080 2_50	70	100	250	4000	6000	5'	3'	6.5	400	2500	3000	94
TR 080 2_70	70	100	250	4000	6000	5'	3'	6.5	400	2500	3000	94
TR 080 2_100	40	80	180	4000	6000	5'	3'	6.5	400	2500	3000	94
TR 080 3_48	70	100	250	3100	4500	7'	5'	5.5	400	2500	3000	90
TR 080 3_64	70	100	250	3100	4500	7'	5'	5.5	400	2500	3000	90
TR 080 3_75	70	100	250	3200	4500	7'	5'	5.5	400	2500	3000	90
TR 080 3_80	70	100	250	3100	4500	7'	5'	5.5	400	2500	3000	90
TR 080 3_84	70	100	250	4000	6000	7'	5'	5.5	400	2500	3000	90
TR 080 3_90	40	80	180	4000	6000	7'	5'	5.5	400	2500	3000	90
TR 080 3_120	70	100	250	4000	6000	7'	5'	5.5	400	2500	3000	90
TR 080 3_125	70	100	250	3200	4500	7'	5'	5.5	400	2500	3000	90
TR 080 3_140	70	100	250	4000	6000	7'	5'	5.5	400	2500	3000	90
TR 080 3_150	70	100	250	4000	6000	7'	5'	5.5	400	2500	3000	90
TR 080 3_160	70	100	250	4000	6000	7'	5'	5.5	400	2500	3000	90
TR 080 3_175	70	100	250	4000	6000	7'	5'	5.5	400	2500	3000	90
TR 080 3_200	70	100	250	4000	6000	7'	5'	5.5	400	2500	3000	90
TR 080 3_210	70	100	250	4000	6000	7'	5'	5.5	400	2500	3000	90
TR 080 3_216	70	100	250	3200	4500	7'	5'	5.5	400	2500	3000	90
TR 080 3_250	70	100	250	4000	6000	7'	5'	5.5	400	2500	3000	90
TR 080 3_280	70	100	250	4000	6000	7'	5'	5.5	400	2500	3000	90
TR 080 3_350	70	100	250	4000	6000	7'	5'	5.5	400	2500	3000	90
TR 080 3_400	70	100	250	4000	6000	7'	5'	5.5	400	2500	3000	90
TR 080 3_500	70	100	250	4000	6000	7'	5'	5.5	400	2500	3000	90
TR 080 3_700	70	100	250	4000	6000	7'	5'	5.5	400	2500	3000	90
TR 080 3_1000	40	80	180	4000	6000	7'	5'	5.5	400	2500	3000	90

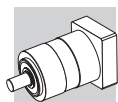

## 2.4 TR 105

TR 105												
i	M <sub>n2</sub> [Nm]	M <sub>a2</sub> [Nm]	M <sub>p2</sub> [Nm]	n <sub>1</sub> [min <sup>-1</sup> ]	n <sub>1max</sub> [min <sup>-1</sup> ]	φ <sub>S</sub> [arcmin]	φ <sub>R</sub> [arcmin]	C <sub>t</sub> [Nm/arcmin]	R <sub>n1</sub> [N]	R <sub>n2</sub> [N]	A <sub>n2</sub> [N]	η %
TR 105 1_3	100	180	360	2500	3500	5'	3'	24	600	3800	4000	97
TR 105 1_4	140	210	450	2800	4500	5'	3'	24	600	3800	4000	97
TR 105 1_5	140	210	450	3000	4500	5'	3'	24	600	3800	4000	97
TR 105 1_6	140	210	450	3000	4500	5'	3'	24	600	3800	4000	97
TR 105 1_7	140	210	450	3500	5000	5'	3'	24	600	3800	4000	97
TR 105 1_10	100	180	360	3500	5000	5'	3'	24	600	3800	4000	97
TR 105 2_9	100	180	360	2500	3500	5'	3'	21.5	600	3800	4000	94
TR 105 2_12	170	250	600	2500	3500	5'	3'	21.5	600	3800	4000	94
TR 105 2_15	170	250	600	2500	3500	5'	3'	21.5	600	3800	4000	94
TR 105 2_16	170	250	600	2800	4500	5'	3'	21.5	600	3800	4000	94
TR 105 2_20	170	250	600	3000	4500	5'	3'	21.5	600	3800	4000	94
TR 105 2_25	170	250	600	3000	4500	5'	3'	21.5	600	3800	4000	94
TR 105 2_28	170	250	600	3500	5000	5'	3'	21.5	600	3800	4000	94
TR 105 2_30	100	180	360	3500	5000	5'	3'	21.5	600	3800	4000	94
TR 105 2_35	170	250	600	3500	5000	5'	3'	21.5	600	3800	4000	94
TR 105 2_36	140	210	450	3000	4500	5'	3'	21.5	600	3800	4000	94
TR 105 2_40	170	250	600	3500	5000	5'	3'	21.5	600	3800	4000	94
TR 105 2_50	170	250	600	3500	5000	5'	3'	21.5	600	3800	4000	94
TR 105 2_70	170	250	600	3500	5000	5'	3'	21.5	600	3800	4000	94
TR 105 2_100	100	180	360	3500	5000	5'	3'	21.5	600	3800	4000	94
TR 105 3_48	170	250	600	2800	4500	7'	5'	18	600	3800	4000	90
TR 105 3_64	170	250	600	2800	4500	7'	5'	18	600	3800	4000	90
TR 105 3_75	170	250	600	3000	4500	7'	5'	18	600	3800	4000	90
TR 105 3_80	170	250	600	2800	4500	7'	5'	18	600	3800	4000	90
TR 105 3_84	170	250	600	3500	5000	7'	5'	18	600	3800	4000	90
TR 105 3_90	100	180	360	3500	5000	7'	5'	18	600	3800	4000	90
TR 105 3_120	170	250	600	3500	5000	7'	5'	18	600	3800	4000	90
TR 105 3_125	170	250	600	3000	4500	7'	5'	18	600	3800	4000	90
TR 105 3_140	170	250	600	3500	5000	7'	5'	18	600	3800	4000	90
TR 105 3_150	170	250	600	3500	5000	7'	5'	18	600	3800	4000	90
TR 105 3_160	170	250	600	3500	5000	7'	5'	18	600	3800	4000	90
TR 105 3_175	170	250	600	3500	5000	7'	5'	18	600	3800	4000	90
TR 105 3_200	170	250	600	3500	5000	7'	5'	18	600	3800	4000	90
TR 105 3_210	170	250	600	3500	5000	7'	5'	18	600	3800	4000	90
TR 105 3_216	170	250	600	3000	4500	7'	5'	18	600	3800	4000	90
TR 105 3_250	170	250	600	3500	5000	7'	5'	18	600	3800	4000	90
TR 105 3_280	170	250	600	3500	5000	7'	5'	18	600	3800	4000	90
TR 105 3_350	170	250	600	3500	5000	7'	5'	18	600	3800	4000	90
TR 105 3_400	170	250	600	3500	5000	7'	5'	18	600	3800	4000	90
TR 105 3_500	170	250	600	3500	5000	7'	5'	18	600	3800	4000	90
TR 105 3_700	170	250	600	3500	5000	7'	5'	18	600	3800	4000	90
TR 105 3_1000	100	180	360	3500	5000	7'	5'	18	600	3800	4000	90

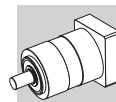

## 2.5 TR 130

TR 130												
i	M <sub>n2</sub> [Nm]	M <sub>a2</sub> [Nm]	M <sub>p2</sub> [Nm]	n <sub>1</sub> [min <sup>-1</sup> ]	n <sub>1max</sub> [min <sup>-1</sup> ]	φ <sub>S</sub> [arcmin]	φ <sub>R</sub> [arcmin]	C <sub>t</sub> [Nm/arcmin]	R <sub>n1</sub> [N]	R <sub>n2</sub> [N]	A <sub>n2</sub> [N]	η %
TR 130 1_3	215	400	800	2100	3000	5'	3'	45	800	5500	6500	97
TR 130 1_4	380	600	1100	2400	3500	5'	3'	45	800	5500	6500	97
TR 130 1_5	380	600	1100	2900	3500	5'	3'	45	800	5500	6500	97
TR 130 1_6	380	600	1100	2900	3500	5'	3'	45	800	5500	6500	97
TR 130 1_7	380	600	1100	3200	4000	5'	3'	45	800	5500	6500	97
TR 130 1_10	215	400	800	3200	4000	5'	3'	45	800	5500	6500	97
TR 130 2_9	215	400	800	2100	3000	5'	3'	38.5	800	5500	6500	94
TR 130 2_12	450	700	1300	2100	3000	5'	3'	38.5	800	5500	6500	94
TR 130 2_15	450	700	1300	2100	3000	5'	3'	38.5	800	5500	6500	94
TR 130 2_16	450	700	1300	2400	3500	5'	3'	38.5	800	5500	6500	94
TR 130 2_20	450	700	1300	2900	3500	5'	3'	38.5	800	5500	6500	94
TR 130 2_25	450	700	1300	2900	3500	5'	3'	38.5	800	5500	6500	94
TR 130 2_28	450	700	1300	3200	4000	5'	3'	38.5	800	5500	6500	94
TR 130 2_30	215	400	800	3200	4000	5'	3'	38.5	800	5500	6500	94
TR 130 2_35	450	700	1300	3200	4000	5'	3'	38.5	800	5500	6500	94
TR 130 2_36	380	600	1100	2900	3500	5'	3'	38.5	800	5500	6500	94
TR 130 2_40	450	700	1300	3200	4000	5'	3'	38.5	800	5500	6500	94
TR 130 2_50	450	700	1300	3200	4000	5'	3'	38.5	800	5500	6500	94
TR 130 2_70	450	700	1300	3200	4000	5'	3'	38.5	800	5500	6500	94
TR 130 2_100	215	400	800	3200	4000	5'	3'	38.5	800	5500	6500	94
TR 130 3_48	450	700	1300	2400	3500	7'	5'	30	800	5500	6500	90
TR 130 3_64	450	700	1300	2400	3500	7'	5'	30	800	5500	6500	90
TR 130 3_75	450	700	1300	2900	3500	7'	5'	30	800	5500	6500	90
TR 130 3_80	450	700	1300	2400	3500	7'	5'	30	800	5500	6500	90
TR 130 3_84	450	700	1300	3200	4000	7'	5'	30	800	5500	6500	90
TR 130 3_90	215	400	800	3200	4000	7'	5'	30	800	5500	6500	90
TR 130 3_120	450	700	1300	3200	4000	7'	5'	30	800	5500	6500	90
TR 130 3_125	450	700	1300	2900	3500	7'	5'	30	800	5500	6500	90
TR 130 3_140	450	700	1300	3200	4000	7'	5'	30	800	5500	6500	90
TR 130 3_150	450	700	1300	3200	4000	7'	5'	30	800	5500	6500	90
TR 130 3_160	450	700	1300	3200	4000	7'	5'	30	800	5500	6500	90
TR 130 3_175	450	700	1300	3200	4000	7'	5'	30	800	5500	6500	90
TR 130 3_200	450	700	1300	3200	4000	7'	5'	30	800	5500	6500	90
TR 130 3_210	450	700	1300	3200	4000	7'	5'	30	800	5500	6500	90
TR 130 3_216	450	700	1300	2900	3500	7'	5'	30	800	5500	6500	90
TR 130 3_250	450	700	1300	3200	4000	7'	5'	30	800	5500	6500	90
TR 130 3_280	450	700	1300	3200	4000	7'	5'	30	800	5500	6500	90
TR 130 3_350	450	700	1300	3200	4000	7'	5'	30	800	5500	6500	90
TR 130 3_400	450	700	1300	3200	4000	7'	5'	30	800	5500	6500	90
TR 130 3_500	450	700	1300	3200	4000	7'	5'	30	800	5500	6500	90
TR 130 3_700	450	700	1300	3200	4000	7'	5'	30	800	5500	6500	90
TR 130 3_1000	215	400	800	3200	4000	7'	5'	30	800	5500	6500	90

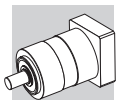

## 2.6 TR 160

TR 160												
i	M <sub>n2</sub> [Nm]	M <sub>a2</sub> [Nm]	M <sub>p2</sub> [Nm]	n <sub>1</sub> [min <sup>-1</sup> ]	n <sub>1max</sub> [min <sup>-1</sup> ]	φ <sub>S</sub> [arcmin]	φ <sub>R</sub> [arcmin]	C <sub>t</sub> [Nm/arcmin]	R <sub>n1</sub> [N]	R <sub>n2</sub> [N]	A <sub>n2</sub> [N]	η %
TR 160 1_3	350	660	1200	1900	3000	5'	3'	90	1200	6500	7500	97
TR 160 1_4	500	750	1400	2200	3500	5'	3'	90	1200	6500	7500	97
TR 160 1_5	500	750	1400	2500	3500	5'	3'	90	1200	6500	7500	97
TR 160 1_6	500	750	1400	2500	3500	5'	3'	90	1200	6500	7500	97
TR 160 1_7	500	750	1400	3000	4000	5'	3'	90	1200	6500	7500	97
TR 160 1_10	350	660	1200	3000	4000	5'	3'	90	1200	6500	7500	97
TR 160 2_9	350	660	1200	1900	3000	5'	3'	83.5	1200	6500	7500	94
TR 160 2_12	700	950	1800	1900	3000	5'	3'	83.5	1200	6500	7500	94
TR 160 2_15	700	950	1800	1900	3000	5'	3'	83.5	1200	6500	7500	94
TR 160 2_16	700	950	1800	2200	3500	5'	3'	83.5	1200	6500	7500	94
TR 160 2_20	700	950	1800	2500	3500	5'	3'	83.5	1200	6500	7500	94
TR 160 2_25	700	950	1800	2500	3500	5'	3'	83.5	1200	6500	7500	94
TR 160 2_28	700	950	1800	3000	4000	5'	3'	83.5	1200	6500	7500	94
TR 160 2_30	350	660	1200	3000	4000	5'	3'	83.5	1200	6500	7500	94
TR 160 2_35	700	950	1800	3000	4000	5'	3'	83.5	1200	6500	7500	94
TR 160 2_36	500	750	1400	2500	3500	5'	3'	83.5	1200	6500	7500	94
TR 160 2_40	700	950	1800	3000	4000	5'	3'	83.5	1200	6500	7500	94
TR 160 2_50	700	950	1800	3000	4000	5'	3'	83.5	1200	6500	7500	94
TR 160 2_70	700	950	1800	3000	4000	5'	3'	83.5	1200	6500	7500	94
TR 160 2_100	350	660	1200	3000	4000	5'	3'	83.5	1200	6500	7500	94
TR 160 3_48	700	950	1800	2200	3500	7'	5'	60	1200	6500	7500	90
TR 160 3_64	700	950	1800	2200	3500	7'	5'	60	1200	6500	7500	90
TR 160 3_75	700	950	1800	2500	3500	7'	5'	60	1200	6500	7500	90
TR 160 3_80	700	950	1800	2200	3500	7'	5'	60	1200	6500	7500	90
TR 160 3_84	700	950	1800	3000	4000	7'	5'	60	1200	6500	7500	90
TR 160 3_90	350	660	1200	3000	4000	7'	5'	60	1200	6500	7500	90
TR 160 3_120	700	950	1800	3000	4000	7'	5'	60	1200	6500	7500	90
TR 160 3_125	700	950	1800	2500	3500	7'	5'	60	1200	6500	7500	90
TR 160 3_140	700	950	1800	3000	4000	7'	5'	60	1200	6500	7500	90
TR 160 3_150	700	950	1800	3000	4000	7'	5'	60	1200	6500	7500	90
TR 160 3_160	700	950	1800	3000	4000	7'	5'	60	1200	6500	7500	90
TR 160 3_175	700	950	1800	3000	4000	7'	5'	60	1200	6500	7500	90
TR 160 3_200	700	950	1800	3000	4000	7'	5'	60	1200	6500	7500	90
TR 160 3_210	700	950	1800	3000	4000	7'	5'	60	1200	6500	7500	90
TR 160 3_216	700	950	1800	2500	3500	7'	5'	60	1200	6500	7500	90
TR 160 3_250	700	950	1800	3000	4000	7'	5'	60	1200	6500	7500	90
TR 160 3_280	700	950	1800	3000	4000	7'	5'	60	1200	6500	7500	90
TR 160 3_350	700	950	1800	3000	4000	7'	5'	60	1200	6500	7500	90
TR 160 3_400	700	950	1800	3000	4000	7'	5'	60	1200	6500	7500	90
TR 160 3_500	700	950	1800	3000	4000	7'	5'	60	1200	6500	7500	90
TR 160 3_700	700	950	1800	3000	4000	7'	5'	60	1200	6500	7500	90
TR 160 3_1000	350	660	1200	3000	4000	7'	5'	60	1200	6500	7500	90

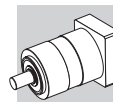

## 2.7 TR 190

TR 190											
i	M <sub>n2</sub> [Nm]	M <sub>a2</sub> [Nm]	M <sub>p2</sub> [Nm]	n <sub>1</sub> [min <sup>-1</sup> ]	n <sub>1max</sub> [min <sup>-1</sup> ]	φ <sub>S</sub> [arcmin]	φ <sub>R</sub> [arcmin]	C <sub>t</sub> [Nm/arcmin]	R <sub>n2</sub> [N]	A <sub>n2</sub> [N]	η %
TR 190 1_3	500	800	1400	1500	2500	5'	3'	130	14000	15000	97
TR 190 1_4	700	950	1800	2100	3000	5'	3'	130	14000	15000	97
TR 190 1_5	700	950	1800	2300	3000	5'	3'	130	14000	15000	97
TR 190 1_6	700	950	1800	2300	3000	5'	3'	130	14000	15000	97
TR 190 1_7	700	950	1800	2900	3500	5'	3'	130	14000	15000	97
TR 190 1_10	500	800	1400	2900	3500	5'	3'	130	14000	15000	97
TR 190 2_9	500	800	1400	1500	2500	5'	3'	100	14000	15000	94
TR 190 2_12	1000	1200	2200	1500	2500	5'	3'	100	14000	15000	94
TR 190 2_15	1000	1200	2200	1500	2500	5'	3'	100	14000	15000	94
TR 190 2_16	1000	1200	2200	2100	3000	5'	3'	100	14000	15000	94
TR 190 2_20	1000	1200	2200	2300	3000	5'	3'	100	14000	15000	94
TR 190 2_25	1000	1200	2200	2300	3000	5'	3'	100	14000	15000	94
TR 190 2_28	1000	1200	2200	2900	3500	5'	3'	100	14000	15000	94
TR 190 2_30	500	800	1400	2900	3500	5'	3'	100	14000	15000	94
TR 190 2_35	1000	1200	2200	2900	3500	5'	3'	100	14000	15000	94
TR 190 2_36	700	950	1800	2300	3000	5'	3'	100	14000	15000	94
TR 190 2_40	1000	1200	2200	2900	3500	5'	3'	100	14000	15000	94
TR 190 2_50	1000	1200	2200	2900	3500	5'	3'	100	14000	15000	94
TR 190 2_70	1000	1200	2200	2900	3500	5'	3'	100	14000	15000	94
TR 190 2_100	500	800	1400	2900	3500	5'	3'	100	14000	15000	94
TR 190 3_48	1000	1200	2200	2100	3000	7'	5'	90	14000	15000	90
TR 190 3_64	1000	1200	2200	2100	3000	7'	5'	90	14000	15000	90
TR 190 3_75	1000	1200	2200	2300	3000	7'	5'	90	14000	15000	90
TR 190 3_80	1000	1200	2200	2100	3000	7'	5'	90	14000	15000	90
TR 190 3_84	1000	1200	2200	2900	3500	7'	5'	90	14000	15000	90
TR 190 3_90	500	800	1400	2900	3500	7'	5'	90	14000	15000	90
TR 190 3_120	1000	1200	2200	2900	3500	7'	5'	90	14000	15000	90
TR 190 3_125	1000	1200	2200	2300	3000	7'	5'	90	14000	15000	90
TR 190 3_140	1000	1200	2200	2900	3500	7'	5'	90	14000	15000	90
TR 190 3_150	1000	1200	2200	2900	3500	7'	5'	90	14000	15000	90
TR 190 3_160	1000	1200	2200	2900	3500	7'	5'	90	14000	15000	90
TR 190 3_175	1000	1200	2200	2900	3500	7'	5'	90	14000	15000	90
TR 190 3_200	1000	1200	2200	2900	3500	7'	5'	90	14000	15000	90
TR 190 3_210	1000	1200	2200	2900	3500	7'	5'	90	14000	15000	90
TR 190 3_250	1000	1200	2200	2900	3500	7'	5'	90	14000	15000	90
TR 190 3_280	1000	1200	2200	2900	3500	7'	5'	90	14000	15000	90
TR 190 3_350	1000	1200	2200	2900	3500	7'	5'	90	14000	15000	90
TR 190 3_400	1000	1200	2200	2900	3500	7'	5'	90	14000	15000	90
TR 190 3_500	1000	1200	2200	2900	3500	7'	5'	90	14000	15000	90
TR 190 3_700	1000	1200	2200	2900	3500	7'	5'	90	14000	15000	90
TR 190 3_1000	500	800	1400	2900	3500	7'	5'	90	14000	15000	90

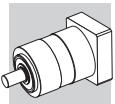

## 2.8 AXIAL- UND RADIALKRAFT AUSFÜHRUNG TR ... MB

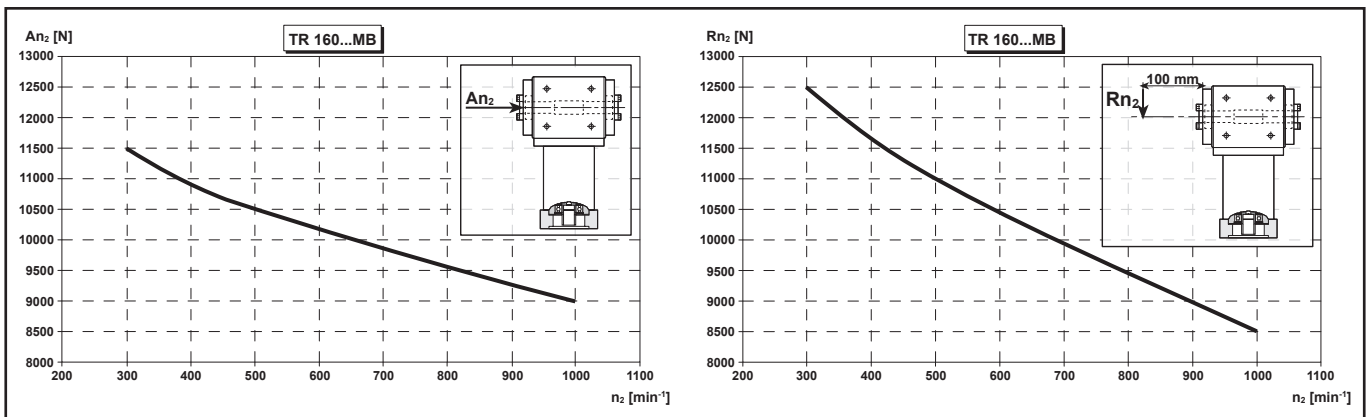
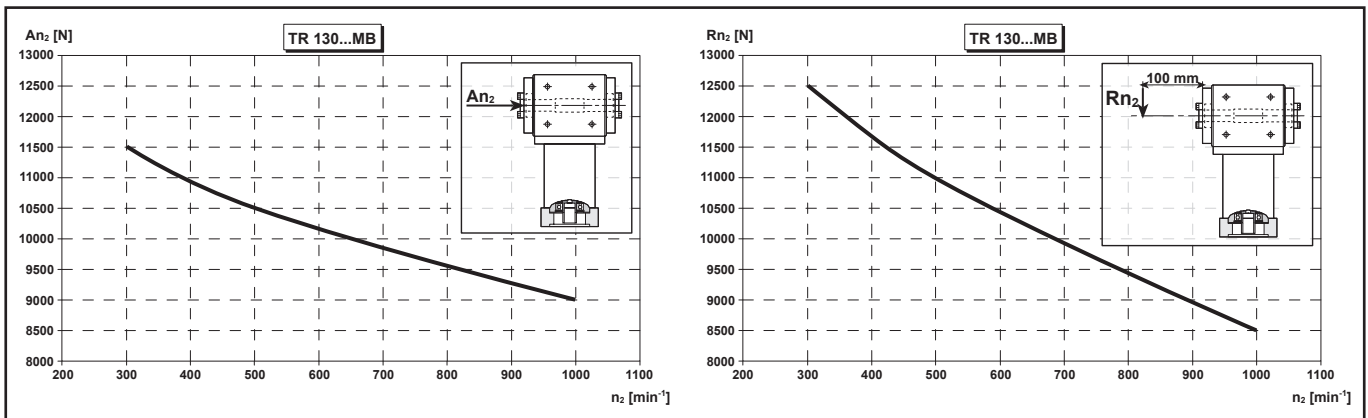
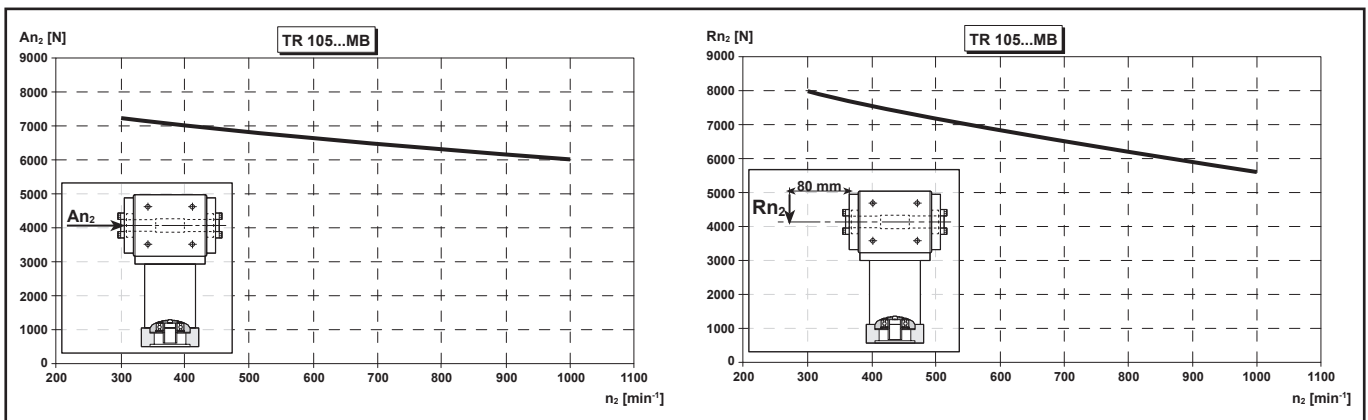
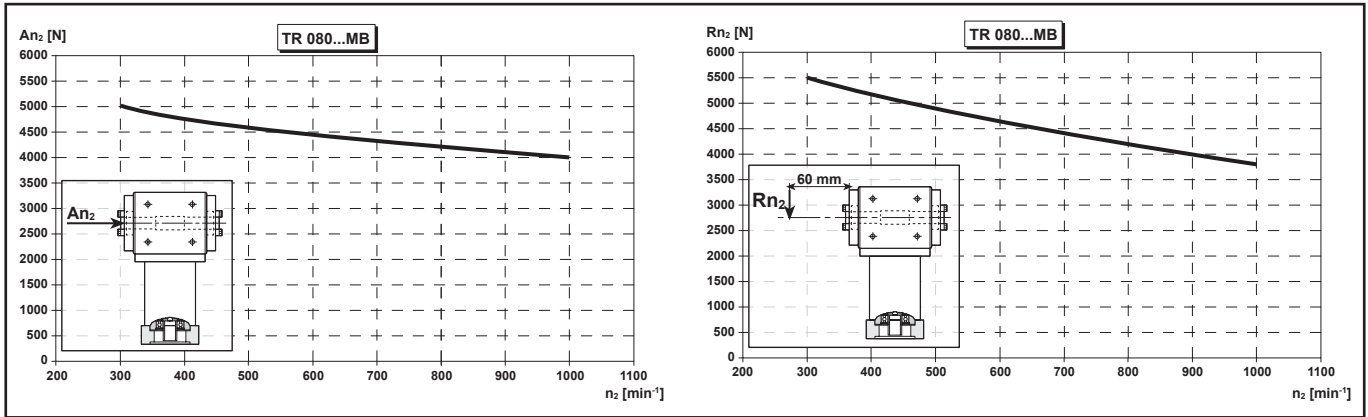

Axialkräfte bezogen auf durchschnittliche Lebensdauer von 10.000 h

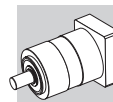

## 2.9 TRÄGHEITSMOMENT

### 2.9.1 TR 053

TR 053		
i	J [kgcm <sup>2</sup> ]	
	D = Ø6...Ø9.52	D = Ø11...Ø14
TR 053 1_3	0.06	0.08
TR 053 1_4	0.05	0.06
TR 053 1_5	0.04	0.06
TR 053 1_6	0.03	0.05
TR 053 1_7	0.03	0.05
TR 053 1_9	0.03	0.05
TR 053 2_12	0.06	0.08
TR 053 2_15	0.06	0.08
TR 053 2_16	0.05	0.06
TR 053 2_20	0.04	0.06
TR 053 2_25	0.04	0.06
TR 053 2_28	0.03	0.05
TR 053 2_35	0.03	0.05
TR 053 2_36	0.03	0.05
TR 053 2_45	0.03	0.05
TR 053 2_81	0.03	0.05
TR 053 3_48	0.05	0.07
TR 053 3_60	0.05	0.07
TR 053 3_64	0.05	0.06
TR 053 3_75	0.04	0.06
TR 053 3_80	0.05	0.06
TR 053 3_84	0.03	0.05
TR 053 3_100	0.04	0.06
TR 053 3_112	0.03	0.05
TR 053 3_125	0.04	0.06
TR 053 3_140	0.03	0.05
TR 053 3_144	0.03	0.05
TR 053 3_175	0.03	0.05
TR 053 3_180	0.03	0.05
TR 053 3_216	0.03	0.05
TR 053 3_225	0.03	0.05
TR 053 3_245	0.03	0.05
TR 053 3_252	0.05	0.06
TR 053 3_324	0.03	0.05
TR 053 3_405	0.03	0.05
TR 053 3_567	0.03	0.05
TR 053 3_729	0.03	0.05

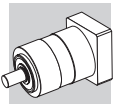

## 2.9.2 TR 060

TR 060		
i	J [kgcm <sup>2</sup> ]	
	D = Ø6...Ø9.52	D = Ø11...Ø14
TR 060 1_3	0.10	0.11
TR 060 1_4	0.06	0.08
TR 060 1_5	0.05	0.07
TR 060 1_6	0.04	0.06
TR 060 1_7	0.04	0.06
TR 060 1_10	0.03	0.05
TR 060 2_9	0.10	0.12
TR 060 2_12	0.10	0.11
TR 060 2_15	0.09	0.11
TR 060 2_16	0.06	0.08
TR 060 2_20	0.05	0.07
TR 060 2_25	0.05	0.06
TR 060 2_28	0.04	0.06
TR 060 2_30	0.03	0.05
TR 060 2_35	0.04	0.06
TR 060 2_36	0.04	0.06
TR 060 2_40	0.03	0.05
TR 060 2_50	0.03	0.05
TR 060 2_70	0.03	0.05
TR 060 2_100	0.03	0.05
TR 060 3_48	0.06	0.08
TR 060 3_64	0.06	0.08
TR 060 3_75	0.05	0.07
TR 060 3_80	0.06	0.08
TR 060 3_84	0.04	0.06
TR 060 3_90	0.03	0.05
TR 060 3_120	0.03	0.05
TR 060 3_125	0.05	0.07
TR 060 3_140	0.04	0.06
TR 060 3_150	0.03	0.05
TR 060 3_160	0.03	0.05
TR 060 3_175	0.04	0.06
TR 060 3_200	0.03	0.05
TR 060 3_210	0.03	0.05
TR 060 3_216	0.04	0.06
TR 060 3_250	0.03	0.05
TR 060 3_280	0.03	0.05
TR 060 3_350	0.03	0.05
TR 060 3_400	0.03	0.05
TR 060 3_500	0.03	0.05
TR 060 3_700	0.03	0.05
TR 060 3_1000	0.03	0.05

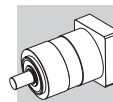

### 2.9.3 TR 080

TR 080		
i	J [kgcm <sup>2</sup> ]	
	D = Ø8...Ø12.7	D = Ø14...Ø19
TR 080 1_3	0.50	0.59
TR 080 1_4	0.34	0.43
TR 080 1_5	0.28	0.37
TR 080 1_6	0.21	0.30
TR 080 1_7	0.23	0.32
TR 080 1_10	0.20	0.29
TR 080 2_9	0.49	0.58
TR 080 2_12	0.47	0.56
TR 080 2_15	0.46	0.55
TR 080 2_16	0.32	0.41
TR 080 2_20	0.27	0.36
TR 080 2_25	0.27	0.36
TR 080 2_28	0.22	0.31
TR 080 2_30	0.20	0.29
TR 080 2_35	0.22	0.31
TR 080 2_36	0.20	0.29
TR 080 2_40	0.20	0.29
TR 080 2_50	0.19	0.28
TR 080 2_70	0.19	0.28
TR 080 2_100	0.19	0.28
TR 080 3_48	0.33	0.42
TR 080 3_64	0.32	0.41
TR 080 3_75	0.27	0.36
TR 080 3_80	0.32	0.41
TR 080 3_84	0.23	0.32
TR 080 3_90	0.20	0.29
TR 080 3_120	0.20	0.29
TR 080 3_125	0.27	0.36
TR 080 3_140	0.22	0.31
TR 080 3_150	0.20	0.29
TR 080 3_160	0.20	0.29
TR 080 3_175	0.22	0.31
TR 080 3_200	0.20	0.29
TR 080 3_210	0.20	0.29
TR 080 3_216	0.20	0.29
TR 080 3_250	0.19	0.28
TR 080 3_280	0.19	0.28
TR 080 3_350	0.19	0.28
TR 080 3_400	0.19	0.28
TR 080 3_500	0.19	0.28
TR 080 3_700	0.19	0.28
TR 080 3_1000	0.19	0.28

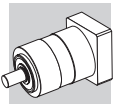

## 2.9.4 TR 105

TR 105				
i	J [kgcm <sup>2</sup> ]			
	D = Ø11...Ø12.7	D = Ø14...Ø19	D = Ø22...Ø24	D = Ø28...Ø32
TR 105 1_3	1.7	1.8	2.2	2.6
TR 105 1_4	0.99	1.1	1.5	1.9
TR 105 1_5	0.72	0.79	1.23	1.6
TR 105 1_6	0.36	0.43	0.88	1.2
TR 105 1_7	0.47	0.55	0.99	1.4
TR 105 1_10	0.33	0.41	0.85	1.2
TR 105 2_9	1.6	1.6	2.1	2.4
TR 105 2_12	1.5	1.6	2.0	2.4
TR 105 2_15	1.5	1.5	2.0	2.4
TR 105 2_16	0.87	0.95	1.4	1.8
TR 105 2_20	0.86	0.93	1.4	1.7
TR 105 2_25	0.63	0.71	1.1	1.5
TR 105 2_28	0.43	0.51	0.95	1.3
TR 105 2_30	0.32	0.40	0.84	1.2
TR 105 2_35	0.43	0.50	0.95	1.3
TR 105 2_36	0.32	0.39	0.84	1.2
TR 105 2_40	0.31	0.39	0.83	1.2
TR 105 2_50	0.31	0.39	0.83	1.2
TR 105 2_70	0.31	0.38	0.83	1.2
TR 105 2_100	0.31	0.38	0.83	1.2
TR 105 3_48	0.91	0.98	1.4	1.8
TR 105 3_64	0.87	0.94	1.4	1.7
TR 105 3_75	0.66	0.74	1.2	1.5
TR 105 3_80	0.86	0.94	1.4	1.7
TR 105 3_84	0.44	0.52	0.96	1.3
TR 105 3_90	0.32	0.39	0.84	1.2
TR 105 3_120	0.32	0.39	0.84	1.2
TR 105 3_125	0.63	0.70	1.1	1.5
TR 105 3_140	0.43	0.51	0.95	1.3
TR 105 3_150	0.32	0.39	0.84	1.2
TR 105 3_160	0.31	0.39	0.83	1.2
TR 105 3_175	0.43	0.50	0.95	1.3
TR 105 3_200	0.31	0.39	0.83	1.2
TR 105 3_210	0.32	0.39	0.84	1.2
TR 105 3_216	0.31	0.39	0.83	1.2
TR 105 3_250	0.31	0.39	0.83	1.2
TR 105 3_280	0.31	0.38	0.83	1.2
TR 105 3_350	0.31	0.38	0.83	1.2
TR 105 3_400	0.31	0.38	0.83	1.2
TR 105 3_500	0.31	0.38	0.83	1.2
TR 105 3_700	0.31	0.38	0.83	1.2
TR 105 3_1000	0.31	0.38	0.83	1.2

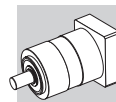

## 2.9.5 TR 130

TR 130				
i	J [kgcm <sup>2</sup> ]			
	D = Ø14...Ø19	D = Ø22...Ø24	D = Ø28...Ø32	D = Ø35...Ø38
TR 130 1_3	5.3	5.5	5.8	7.2
TR 130 1_4	3.1	3.3	3.6	5.0
TR 130 1_5	2.2	2.4	2.8	4.1
TR 130 1_6	1.2	1.4	1.7	3.1
TR 130 1_7	1.5	1.7	2.0	3.4
TR 130 1_10	1.0	1.2	1.6	3.0
TR 130 2_9	4.8	5.0	5.4	6.7
TR 130 2_12	4.6	4.8	5.1	6.5
TR 130 2_15	4.5	4.7	5.0	6.4
TR 130 2_16	2.7	2.9	3.2	4.6
TR 130 2_20	2.0	2.2	2.5	3.9
TR 130 2_25	1.9	2.1	2.5	3.8
TR 130 2_28	1.3	1.6	1.9	3.3
TR 130 2_30	1.0	1.2	1.6	2.9
TR 130 2_35	1.3	1.5	1.9	3.2
TR 130 2_36	1.1	1.3	1.6	3.0
TR 130 2_40	0.98	1.2	1.5	2.9
TR 130 2_50	0.97	1.2	1.5	2.9
TR 130 2_70	0.96	1.2	1.5	2.9
TR 130 2_100	0.96	1.2	1.5	2.9
TR 130 3_48	2.8	3.0	3.3	4.7
TR 130 3_64	2.6	2.9	3.2	4.6
TR 130 3_75	2.0	2.2	2.6	3.9
TR 130 3_80	2.6	2.9	3.2	4.6
TR 130 3_84	1.4	1.6	1.9	3.3
TR 130 3_90	1.0	1.2	1.6	2.9
TR 130 3_120	0.99	1.2	1.55	2.9
TR 130 3_125	1.9	2.1	2.5	3.8
TR 130 3_140	1.3	1.5	1.9	3.2
TR 130 3_150	0.99	1.2	1.6	2.9
TR 130 3_160	0.98	1.2	1.5	2.9
TR 130 3_175	1.3	1.5	1.9	3.2
TR 130 3_200	0.97	1.2	1.5	2.9
TR 130 3_210	0.99	1.2	1.6	2.9
TR 130 3_216	1.0	1.3	1.6	3.0
TR 130 3_250	0.97	1.2	1.5	2.9
TR 130 3_280	0.96	1.2	1.5	2.9
TR 130 3_350	0.96	1.2	1.5	2.9
TR 130 3_400	0.96	1.2	1.5	2.9
TR 130 3_500	0.96	1.2	1.5	2.9
TR 130 3_700	0.96	1.2	1.5	2.9
TR 130 3_1000	0.96	1.2	1.5	2.9

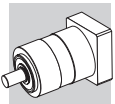

## 2.9.6 TR 160

TR 160				
i	J [kgcm <sup>2</sup> ]			
	D = Ø14...Ø19	D = Ø22...Ø24	D = Ø28...Ø32	D = Ø35...Ø38
TR 160 1_3	8.4	8.6	8.9	10.3
TR 160 1_4	4.7	4.9	5.2	6.6
TR 160 1_5	3.3	3.5	3.8	5.2
TR 160 1_6	1.3	1.5	1.9	3.2
TR 160 1_7	2.0	2.2	2.6	3.9
TR 160 1_10	1.3	1.5	1.9	3.2
TR 160 2_9	7.5	7.7	8.1	9.4
TR 160 2_12	7.1	7.3	7.7	9.0
TR 160 2_15	6.9	7.1	7.5	8.9
TR 160 2_16	4.0	4.2	4.5	5.9
TR 160 2_20	2.8	3.0	3.4	4.7
TR 160 2_25	2.8	3.0	3.3	4.7
TR 160 2_28	1.8	2.0	2.4	3.7
TR 160 2_30	1.2	1.5	1.8	3.2
TR 160 2_35	1.8	2.0	2.3	3.7
TR 160 2_36	1.1	1.3	1.6	3.0
TR 160 2_40	1.2	1.4	1.8	3.1
TR 160 2_50	1.2	1.4	1.8	3.1
TR 160 2_70	1.2	1.4	1.7	3.1
TR 160 2_100	1.2	1.4	1.7	3.1
TR 160 3_48	4.1	4.3	4.7	6.0
TR 160 3_64	3.9	4.1	4.5	5.8
TR 160 3_75	2.9	3.1	3.5	4.8
TR 160 3_80	3.9	4.1	4.5	5.8
TR 160 3_84	1.8	2.1	2.4	3.8
TR 160 3_90	1.2	1.4	1.8	3.1
TR 160 3_120	1.2	1.4	1.8	3.1
TR 160 3_125	2.7	2.9	3.3	4.6
TR 160 3_140	1.8	2.0	2.3	3.7
TR 160 3_150	1.2	1.4	1.8	3.1
TR 160 3_160	1.2	1.4	1.8	3.1
TR 160 3_175	1.8	2.0	2.3	3.7
TR 160 3_200	1.2	1.4	1.8	3.1
TR 160 3_210	1.2	1.4	1.8	3.1
TR 160 3_216	1.1	1.3	1.6	3.0
TR 160 3_250	1.2	1.4	1.7	3.1
TR 160 3_280	1.2	1.4	1.7	3.1
TR 160 3_350	1.2	1.4	1.7	3.1
TR 160 3_400	1.2	1.4	1.7	3.1
TR 160 3_500	1.2	1.4	1.7	3.1
TR 160 3_700	1.2	1.4	1.7	3.1
TR 160 3_1000	1.2	1.4	1.7	3.1

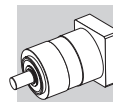

## 2.9.7 TR 190

TR 190					
i	J [kgcm <sup>2</sup> ]				
	D = Ø14...Ø24	D = Ø28...Ø32	D = Ø35...Ø38	D = Ø42	D = Ø45...Ø48
TR 190 1_3	24.2	24.9	25.6	29.3	29.9
TR 190 1_4	13.4	14.1	14.9	18.5	19.1
TR 190 1_5	9.3	10.0	10.8	14.4	15.0
TR 190 1_6	2.9	3.6	4.3	8.0	8.6
TR 190 1_7	5.7	6.4	7.1	10.8	11.4
TR 190 1_10	3.6	4.2	5.0	8.7	9.3
TR 190 2_9	23.2	23.9	24.7	28.3	28.9
TR 190 2_12	22.0	22.7	23.5	27.1	27.7
TR 190 2_15	21.6	22.3	23.0	26.7	27.3
TR 190 2_16	12.2	12.9	13.6	17.3	17.9
TR 190 2_20	8.5	9.2	10.0	13.6	14.2
TR 190 2_25	8.4	9.1	9.8	13.5	14.1
TR 190 2_28	5.3	6.0	6.7	10.4	11.0
TR 190 2_30	3.5	4.2	4.9	8.6	9.2
TR 190 2_35	5.2	5.9	6.6	10.3	10.9
TR 190 2_36	2.2	2.9	3.6	7.3	7.9
TR 190 2_40	3.4	4.1	4.8	8.5	9.1
TR 190 2_50	3.3	4.0	4.8	8.4	9.0
TR 190 2_70	3.3	4.0	4.7	8.4	9.0
TR 190 2_100	3.3	4.0	4.7	8.4	9.0
TR 190 3_48	12.7	13.4	14.2	17.8	18.4
TR 190 3_64	12.1	12.8	13.5	17.2	17.8
TR 190 3_75	8.9	9.5	10.3	14.0	14.6
TR 190 3_80	12.1	12.8	13.5	17.2	17.8
TR 190 3_84	5.5	6.1	6.9	10.6	11.2
TR 190 3_90	3.5	4.1	4.9	8.6	9.2
TR 190 3_120	3.5	4.1	4.9	8.6	9.2
TR 190 3_125	8.3	9.0	9.8	13.4	14.0
TR 190 3_140	5.2	5.9	6.7	10.3	10.9
TR 190 3_150	3.5	4.1	4.9	8.6	9.2
TR 190 3_160	3.4	4.0	4.8	8.5	9.1
TR 190 3_175	5.2	5.9	6.6	10.3	10.9
TR 190 3_200	3.4	4.0	4.8	8.5	9.1
TR 190 3_210	3.5	4.1	4.9	8.6	9.2
TR 190 3_250	3.3	4.0	4.8	8.4	9.0
TR 190 3_280	3.3	4.0	4.7	8.4	9.0
TR 190 3_350	3.3	4.0	4.7	8.4	9.0
TR 190 3_400	3.3	4.0	4.7	8.4	9.0
TR 190 3_500	3.3	4.0	4.7	8.4	9.0
TR 190 3_700	3.3	4.0	4.7	8.4	9.0
TR 190 3_1000	3.3	4.0	4.7	8.4	9.0

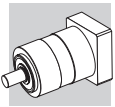

### 3 ABMESSUNGEN

#### 3.1 TR 053

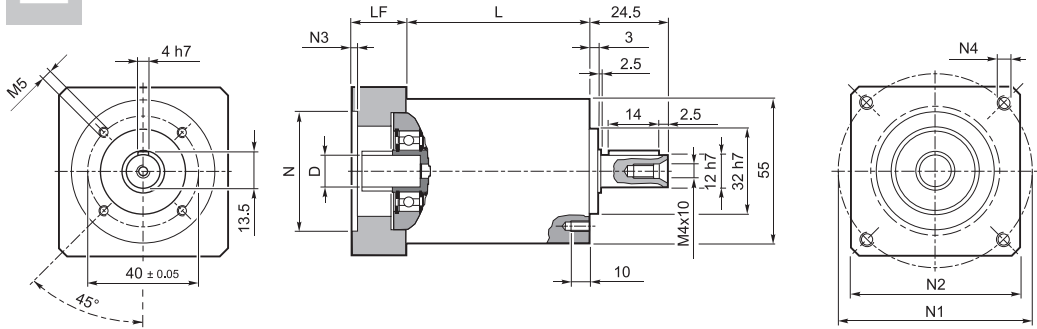

	L	
TR 053 1	53	0.8
TR 053 2	66.8	1.0
TR 053 3	80.6	1.3

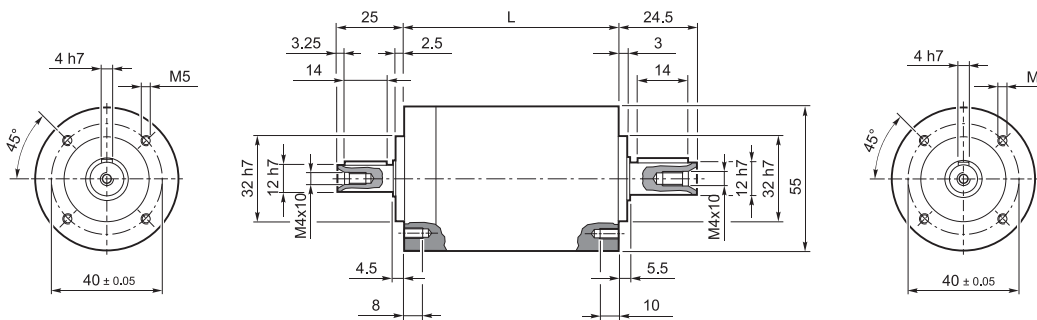
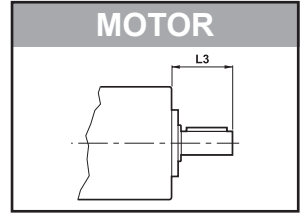

	L	
TR 053 1	58.2	0.8
TR 053 2	72	1.0
TR 053 3	85.8	1.3

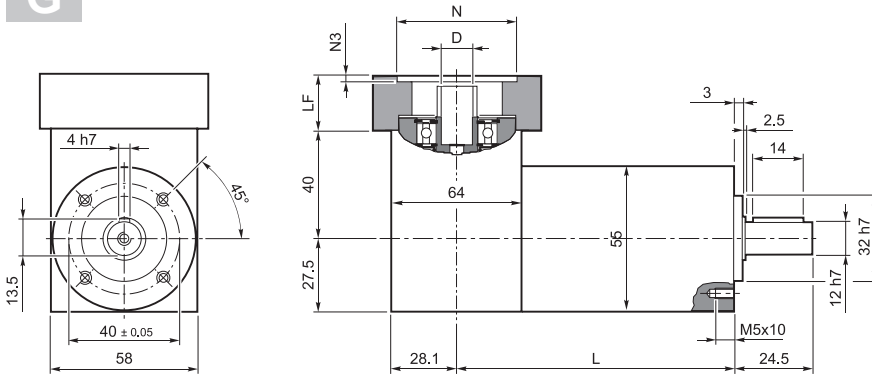

	L	
TR 053 1	88.9	1.3
TR 053 2	102.7	1.5
TR 053 3	116.5	1.8

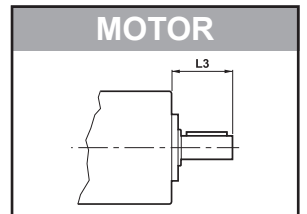

	D	N	N1	N2	N3	N4	LF	L3
TR 053_6...9 25 25...40 36...48	≤ 9 mm	25...40	36...48	55	3.5	4.5	25	25
TR 053_6...12 25 38.1 66.6	≤ 12 mm	38.1	66.6	60	3	M4x10	18	25
TR 053_6...12 25 40 63		40	63	60	3	M4x10	18	25
TR 053_6...12 25 50 60		50	60	60	3	M4x10	18	25
TR 053_6...12 23 50 65 TH		50	65	55	4	5.5	16	23
TR 053_6...12 25 60 75		60	75	63	3	M5x12	18	25
TR 053_6...12 25 60 75 TH*		60	75	65	3	5.5	18	25
TR 053_6...14 30 50 65	≤ 14 mm	50	65	60	3	M5x12	23	30
TR 053_6...14 30 50 65 TH		50	65	60	4	5.5	23	30
TR 053_6...14 30 50 70		50	70	60	3	M4x10	23	30
TR 053_6...14 30 60 75		60	75	63	3	M5x12	23	30
TR 053_6...14 30 60 75 TH*		60	75	65	3	5.5	23	30
TR 053_6...14 30 60 85		60	85	75	3	M5x12	23	30
TR 053_6...14 30 60 90		60	90	75	3	M5x12	23	30
TR 053_6...14 30 70 85		70	85	75	3	M6x15	23	30
TR 053_6...14 30 70 90		70	90	75	3	M5x12	23	30
TR 053_6...14 32 73 98.4		73	98.4	85	3	M5x12	25	32
TR 053_6...14 30 80 100	80	100	85	3	M6x15	23	30	

\* nicht mit Version G verwendbar

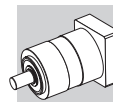

### 3.2 TR 060

**I**

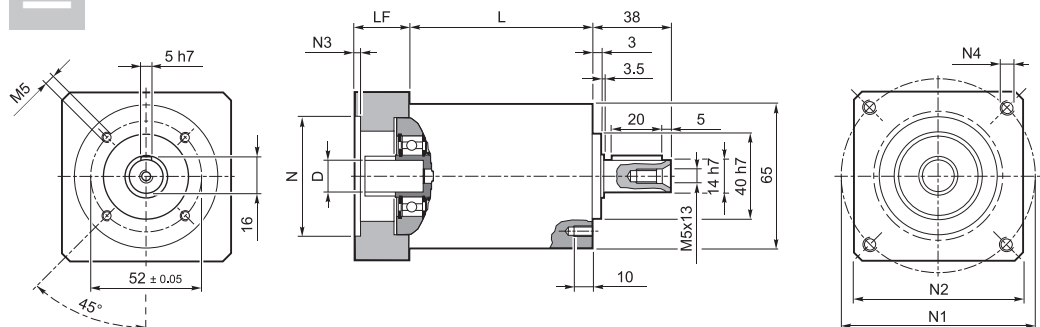

	L	
TR 060 1	57.55	1.2
TR 060 2	74.25	1.7
TR 060 3	90.95	2.0

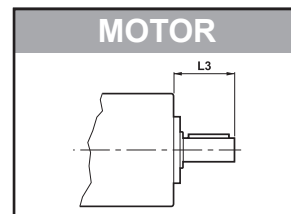

**IS**

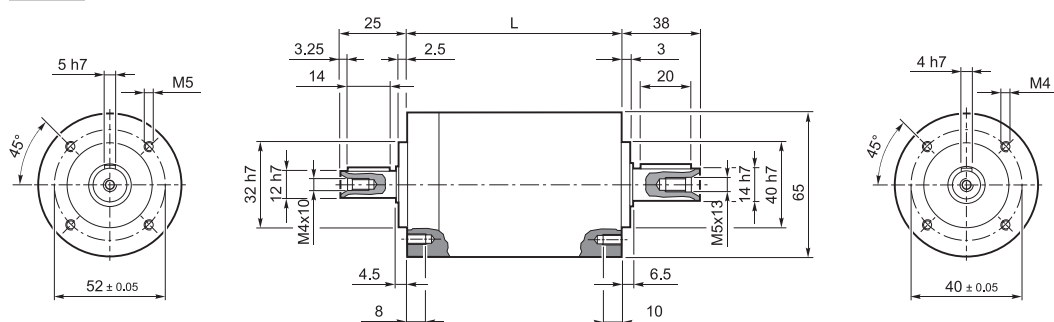

	L	
TR 060 1	62.75	1.2
TR 060 2	79.45	1.7
TR 060 3	96.15	2.0

**G**

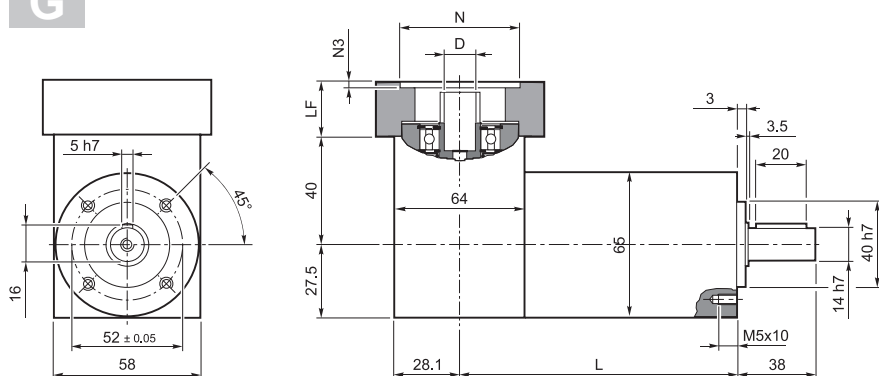

	L	
TR 060 1	93.45	1.7
TR 060 2	110.15	2.2
TR 060 3	126.85	2.5

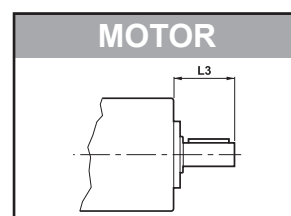

	D	N	N1	N2	N3	N4	LF	L3
TR 060_ 6...9 25 25...40 39...56	≤ 9 mm	25...40	39...56	65	3.5	4.5	25	25
TR 060_ 6...12 25 38.1 66.6	≤ 12 mm	38.1	66.6	60	3	M4x10	18	25
TR 060_ 6...12 25 40 63		40	63	60	3	M4x10	18	25
TR 060_ 6...12 25 50 60		50	60	60	3	M4x10	18	25
TR 060_ 6...12 23 55 80 TH		55	80	65	2	5.5	16	23
TR 060_ 6...12 25 60 75		60	75	63	3	M5x12	18	25
TR 060_ 6...12 25 60 75 TH*		60	75	65	3	5.5	18	25
TR 060_ 6...14 30 50 65	≤ 14 mm	50	65	60	3	M5x12	23	30
TR 060_ 6...14 30 50 65 TH		50	65	60	3	5.5	25	30
TR 060_ 6...14 30 50 70		50	70	60	3	M4x10	23	30
TR 060_ 6...14 30 60 75		60	75	63	3	M5x12	23	30
TR 060_ 6...14 30 60 75 TH*		60	75	65	3	5.5	23	30
TR 060_ 6...14 30 60 85		60	85	75	3	M5x12	23	30
TR 060_ 6...14 30 60 90		60	90	75	3	M5x12	23	30
TR 060_ 6...14 30 70 85		70	85	75	3	M6x15	23	30
TR 060_ 6...14 30 70 90		70	90	75	3	M5x12	23	30
TR 060_ 6...14 32 73 98.4		73	98.4	85	3	M5x12	25	32
TR 060_ 6...14 30 80 100	80	100	85	3	M6x15	23	30	

\* nicht mit Version G verwendbar

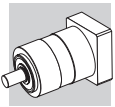

### 3.3 TR 080

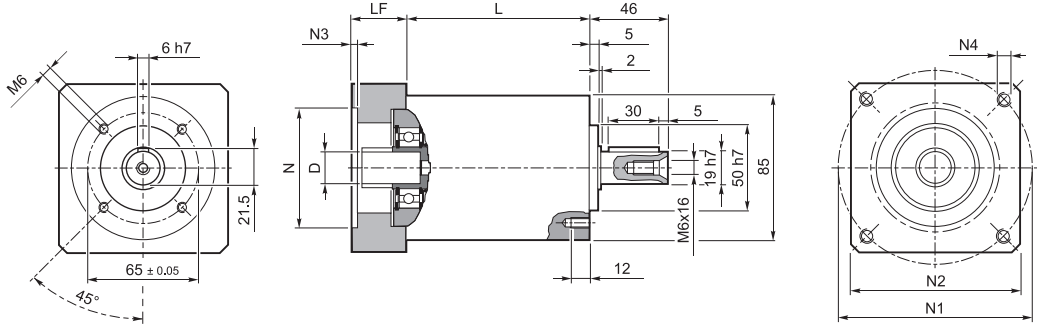

	L	
TR 080 1	83.5	4.0
TR 080 2	108	4.6
TR 080 3	132.5	5.2

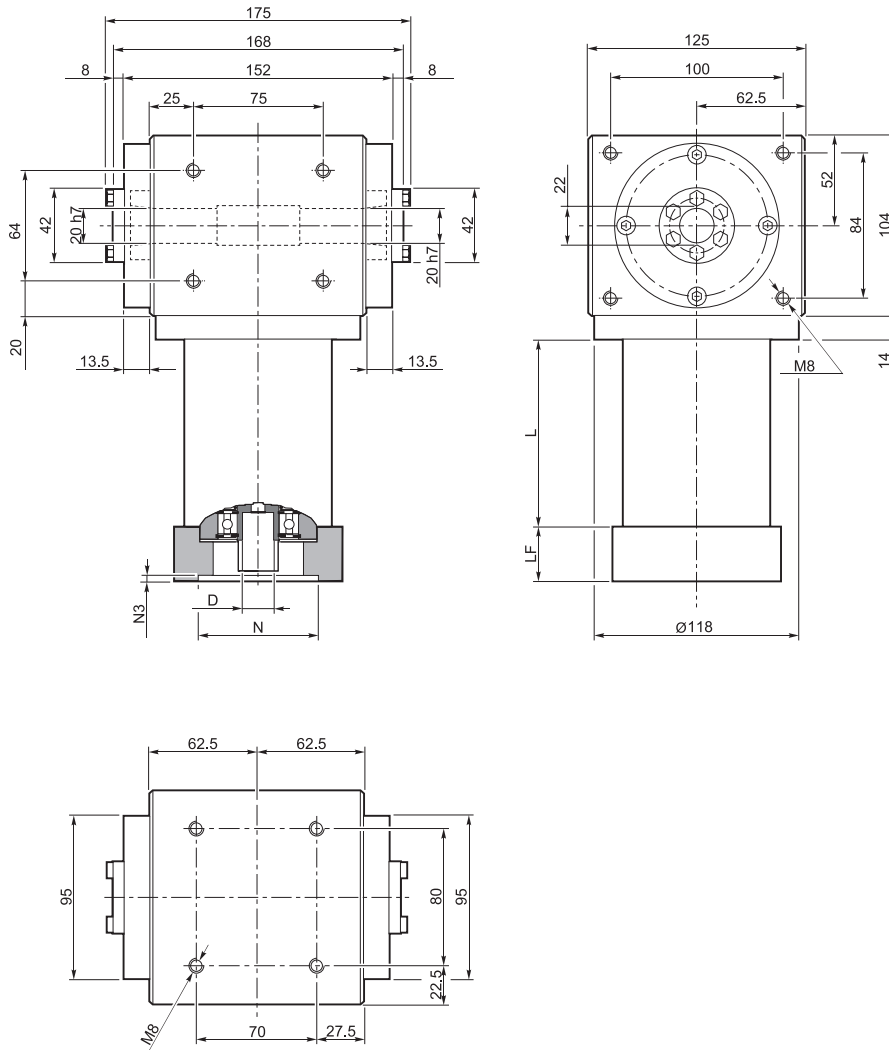
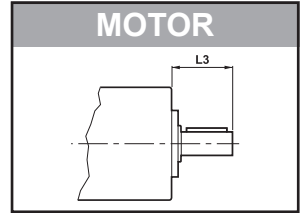

	L	
TR 080 1	83.5	14
TR 080 2	108	15
TR 080 3	132.5	16

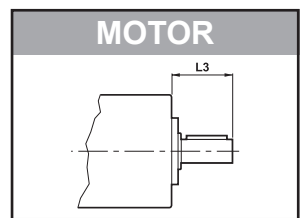

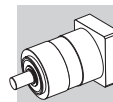

**IS**

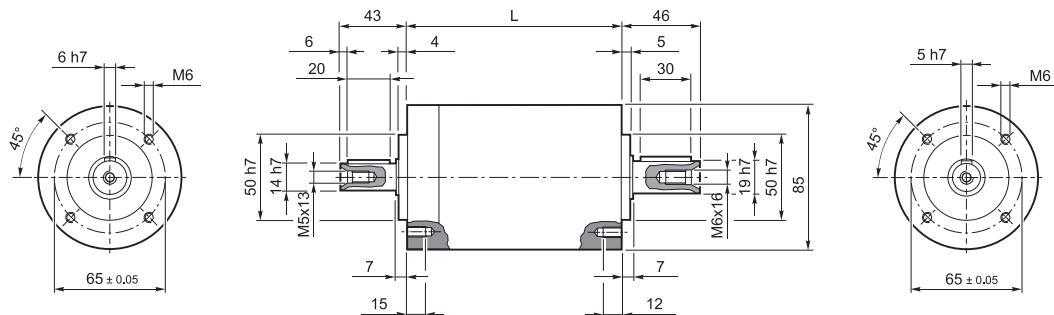

	L	
TR 080 1	105.3	4
TR 080 2	129.8	4.6
TR 080 3	154.3	5.2

**G**

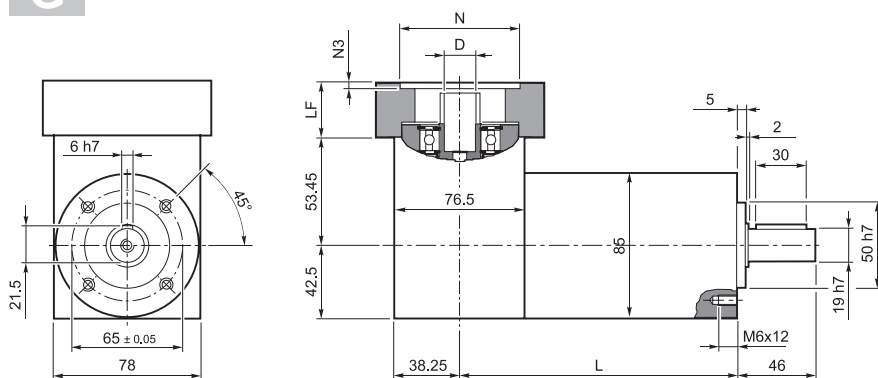

	L	
TR 080 1	143.55	5.2
TR 080 2	168.05	5.8
TR 080 3	192.55	6.4

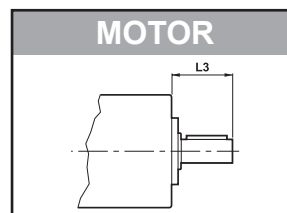

	D	N	N1	N2	N3	N4	LF	L3
TR 080_ 8...12 40 45 63	≤ 12 mm	45	63	80	-	M4x10	34	40
TR 080_ 8...14 40 40 63		40	63	80	-	M4x10	34	40
TR 080_ 8...14 40 50 65		50	65	80	4	M5x16	34	40
TR 080_ 8...14 40 50 65 TH		50	65	80	4	Ø5.5	34	40
TR 080_ 8...14 40 50 70		50	70	80	4	M4x10	34	40
TR 080_ 8...14 40 50 95	≤ 14 mm	50	95	80	4	M6x10	34	40
TR 080_ 8...14 40 60 75		60	75	80	4	M5x16	34	40
TR 080_ 8...14 40 60 75 TH		60	75	80	4	Ø5.5	34	40
TR 080_ 8...14 40 73 98.4		73	98.4	85	4	M5x16	34	40
TR 080_ 8...14 40 78 63.5		78	63.5	90	4	Ø6.5	34	40
TR 080_ 8...16 40 60 85	≤ 16 mm	60	85	80	4	M5x16	34	40
TR 080_ 8...16 40 60 90		60	90	80	4	M5x16	34	40
TR 080_ 8...19 40 55.5 125.7		55.5	125.7	105	4	M6x16	34	40
TR 080_ 8...19 40 70 85		70	85	80	4	M6x20	34	40
TR 080_ 8...19 40 70 85 TH		70	85	80	4	Ø6.5	34	40
TR 080_ 8...19 40 70 90		70	90	80	4	M5x16	34	40
TR 080_ 8...19 40 80 100		80	100	90	4	M6x16	34	40
TR 080_ 8...19 40 95 115	≤ 19 mm	95	115	100	4	M8x20	34	40
TR 080_ 8...19 40 95 130		95	130	115	4	M8x20	34	40
TR 080_ 8...19 40 110 130		110	130	115	4	M8x20	34	40
TR 080_ 8...19 50 110 145		110	145	120	6.5	M8x20	44	50
TR 080_ 8...19 60 110 145		110	145	120	6.5	M8x20	54	60

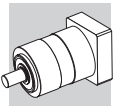

### 3.4 TR 105

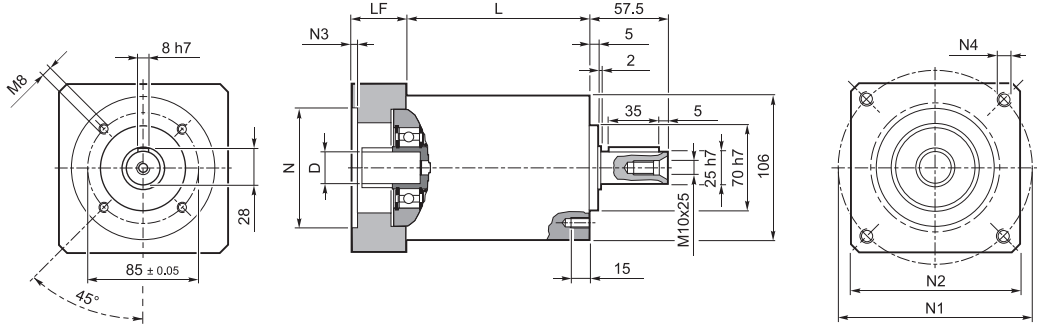

	L	
TR 105 1	107.5	6.5
TR 105 2	140	8.5
TR 105 3	172.5	10.5

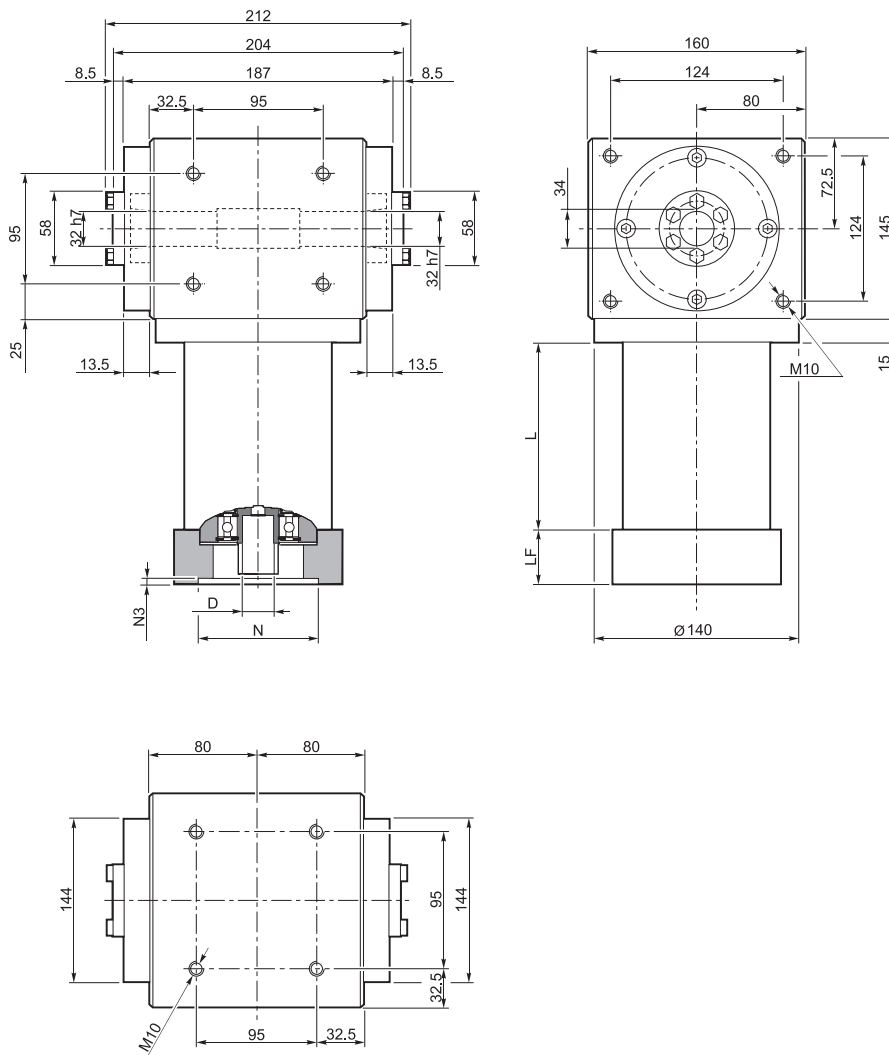
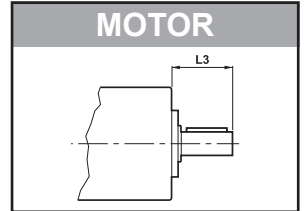

	L	
TR 105 1	107.5	32
TR 105 2	140	34
TR 105 3	172.5	36

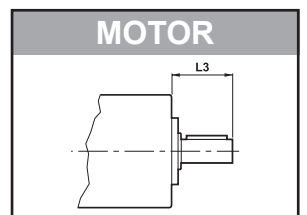

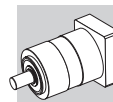

**IS**

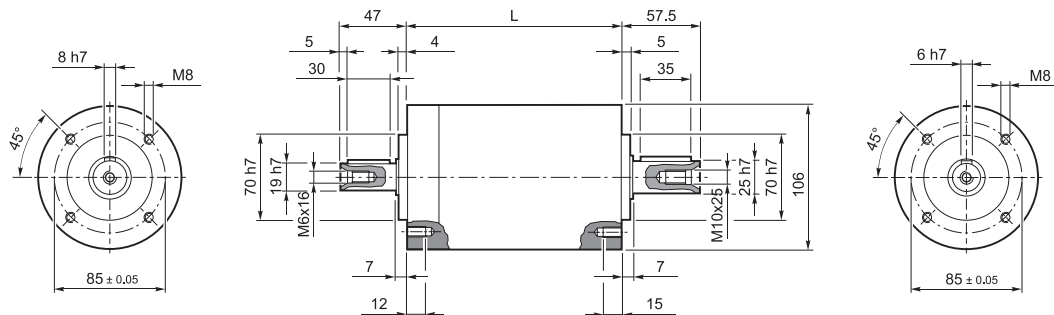

	L	
TR 105 1	121.3	6.5
TR 105 2	153.8	8.5
TR 105 3	186.3	10.5

**G**

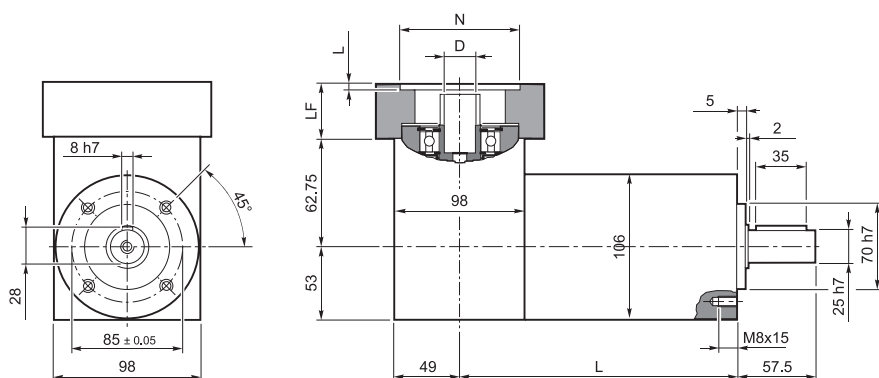

	L	
TR 105 1	170.3	8.5
TR 105 2	202.8	10.5
TR 105 3	235.3	12.5

**MOTOR**

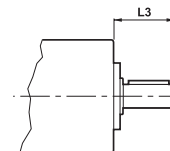

	D	N	N1	N2	N3	N4	LF	L3
TR 105_ 11...19 40 50 95		50	95	100	5	M6x14	28	40
TR 105_ 11...19 40 55.5 125.7		55.5	125.7	105	5	M6x16	28	40
TR 105_ 11...19 40 60 75		60	75	100	5	M5x14	28	40
TR 105_ 11...19 40 60 75 TH		60	75	100	5	5	33	40
TR 105_ 11...19 40 60 85		60	85	100	6.5	M5x14	28	40
TR 105_ 11...19 40 70 85		70	85	100	5	M6x14	28	40
TR 105_ 11...19 40 70 85 TH	≤ 19 mm	70	85	100	5	6	33	40
TR 105_ 11...19 40 70 90		70	90	100	5	M5x12	28	40
TR 105_ 11...19 40 80 100		80	100	100	5	M6x16	28	40
TR 105_ 11...19 40 80 100 TH		80	100	100	5	Ø6.5	28	40
TR 105_ 11...19 40 95 115		95	115	100	5	M8x18	28	40
TR 105_ 11...19 40 95 130		95	130	115	5	M8x18	28	40
TR 105_ 11...19 40 110 130		110	130	115	5	M8x18	28	40
TR 105_ 11...24 50 95 115		95	115	100	5	M8x18	38	50
TR 105_ 11...24 50 110 130		110	130	115	6.5	M8x20	38	50
TR 105_ 11...24 50 110 145	≤ 24 mm	110	145	120	6.5	M8x20	38	50
TR 105_ 11...24 60 110 145		110	145	120	6.5	M8x20	48	60
TR 105_ 11...24 50 130 165		130	165	140	6.5	M10x20	38	50
TR 105_ 11...32 60 130 165	≤ 32 mm	130	165	140	6.5	M10x25	48	60

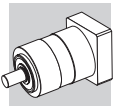

### 3.5 TR 130

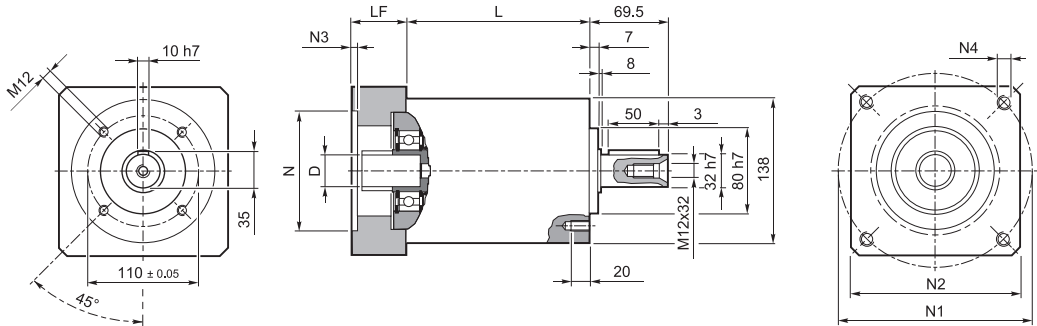

	L	
TR 130 1	126	12
TR 130 2	165.5	15.5
TR 130 3	205	18.5

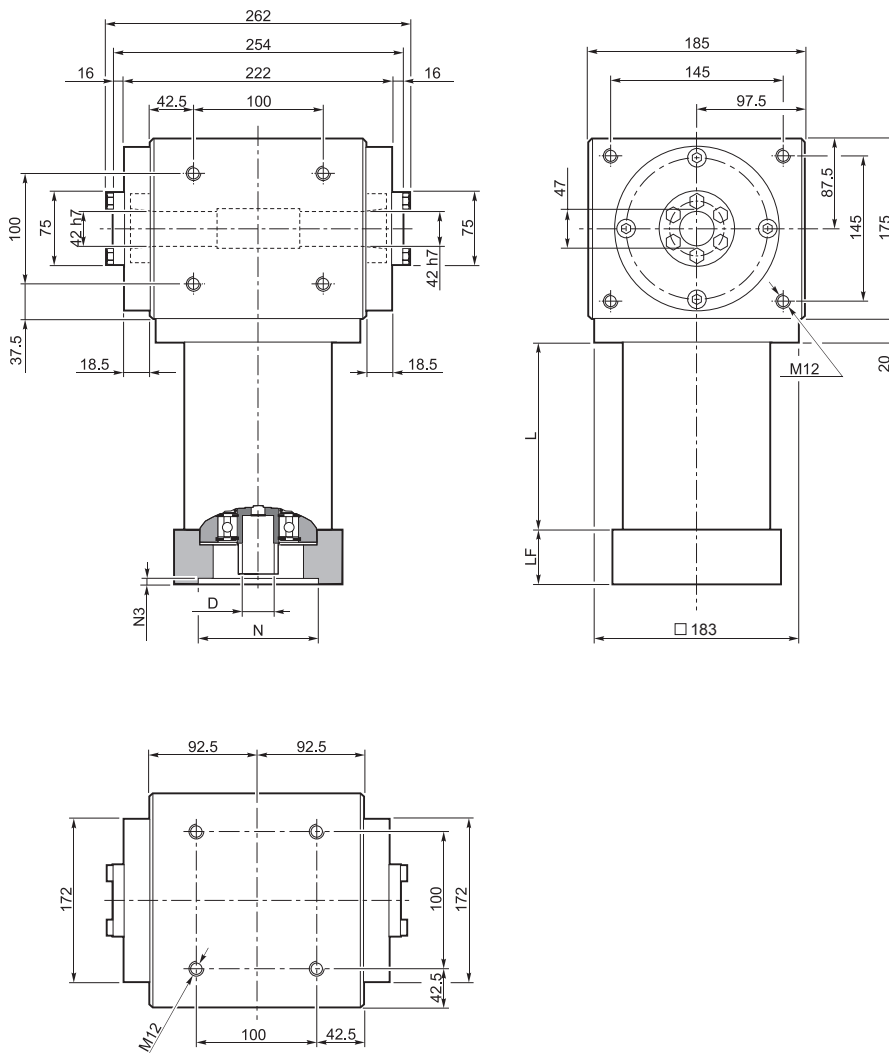
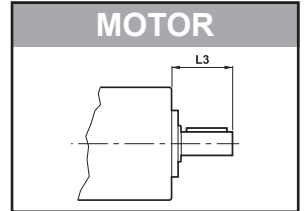

	L	
TR 130 1	126	54
TR 130 2	165.5	58
TR 130 3	205	61

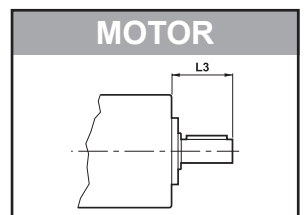

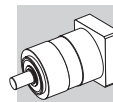

**IS**

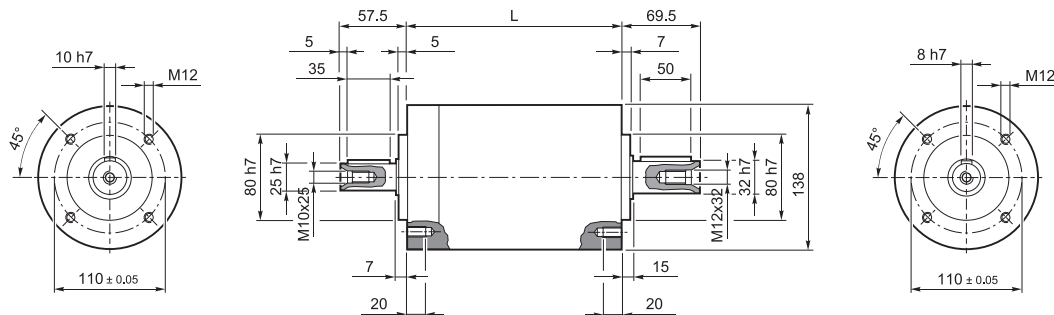

	L	
TR 130 1	151.2	12
TR 130 2	190.7	15.5
TR 130 3	230.2	18.5

**G**

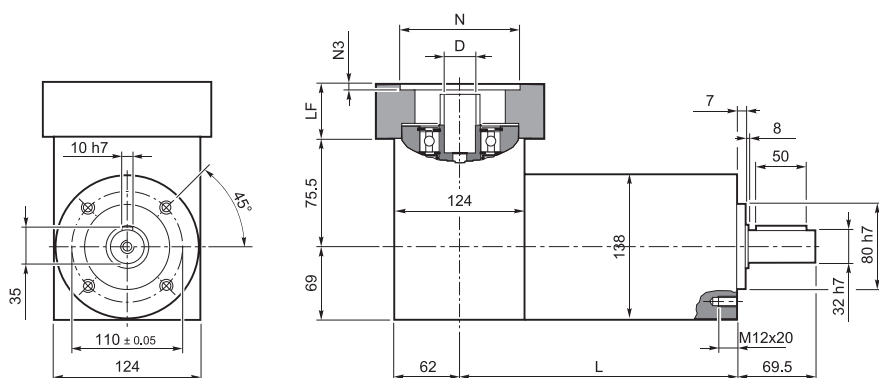

	L	
TR 130 1	213.2	16
TR 130 2	252.7	19.5
TR 130 3	292.2	22.5

**MOTOR**

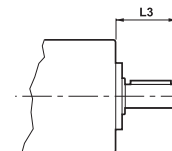

	D	N	N1	N2	N3	N4	LF	L3
TR 130_ 14...19 50 55.5 125.7	≤ 19 mm	55.5	125.7	130	4	M6x15	39.5	50
TR 130_ 14...19 50 80 100		80	100	130	4	M6x15	39.5	50
TR 130_ 14...24 50 95 115	≤ 24 mm	95	115	130	4	M8x20	39.5	50
TR 130_ 14...24 50 110 130		110	130	130	4	M8x20	39.5	50
TR 130_ 14...24 60 110 145		110	145	130	6.5	M8x20	49.5	60
TR 130_ 14...24 50 130 165		130	165	140	4	M10x20	39.5	50
TR 130_ 14...24 80 114.3 200	≤ 38 mm	114.3	200	170	5.5	M14x25	39.5	50
TR 130_ 14...32 60 130 165		130	165	140	4	M10x20	49.5	60
TR 130_ 14...32 60 180 215		180	215	190	5.5	M14x25	49.5	60
TR 130_ 14...38 80 114.3 200		114.3	200	170	5.5	M12x25	69.5	80
TR 130_ 14...38 80 180 215		180	215	190	5.5	M14x25	69.5	80
TR 130_ 14...38 80 114.3 200		114.3	200	170	5.5	M12x25	69.5	80

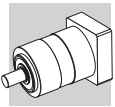

### 3.6 TR 160

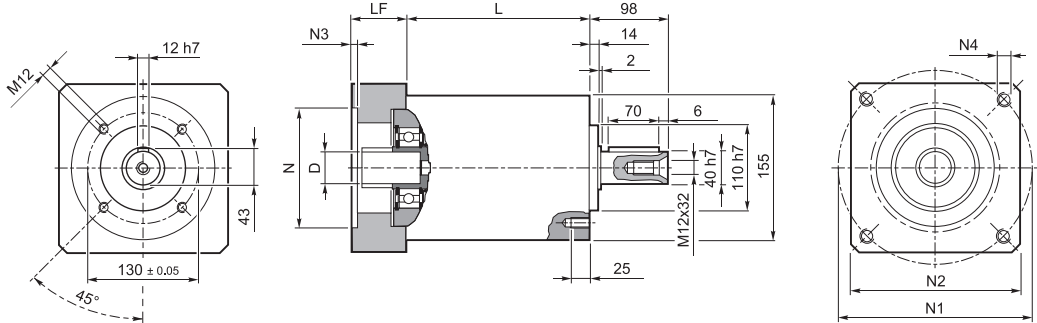

	L	
TR 160 1	130	17
TR 160 2	169.5	21
TR 160 3	209	28

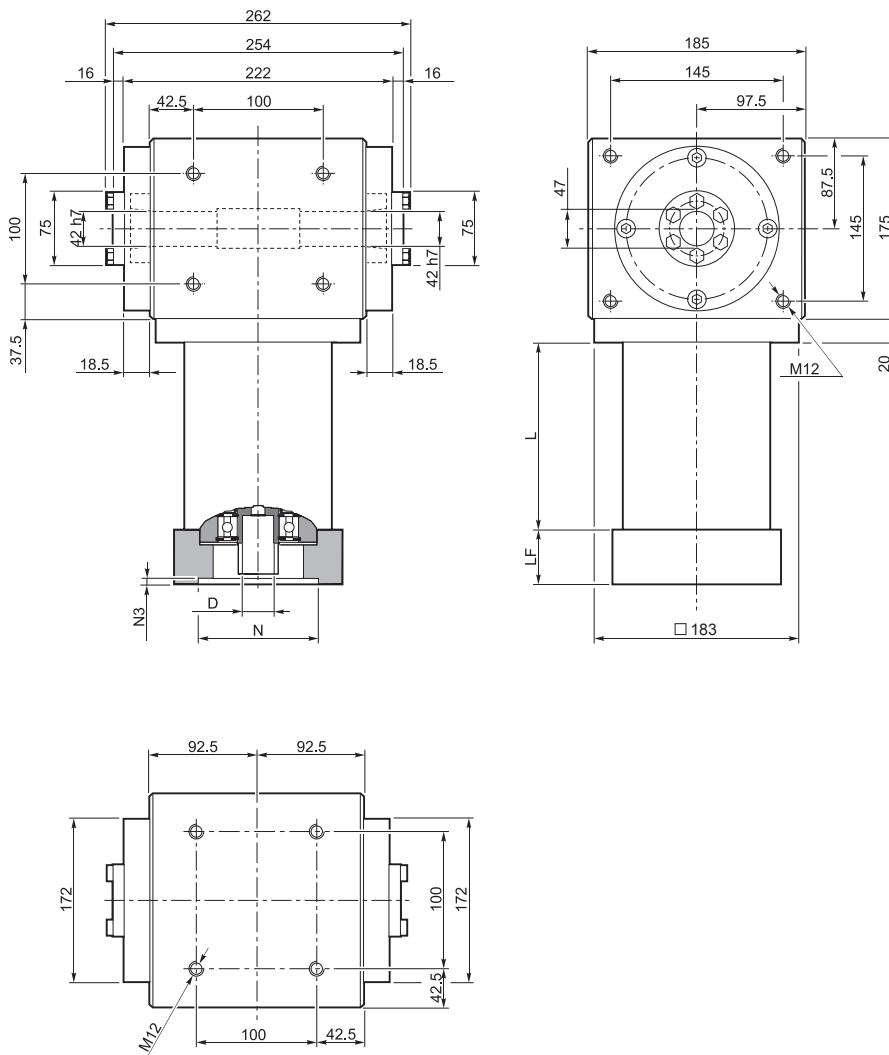
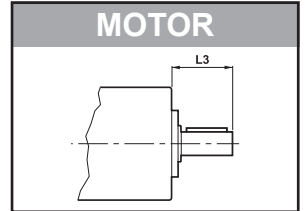

	L	
TR 160 1	130	54
TR 160 2	169.5	58
TR 160 3	209	61

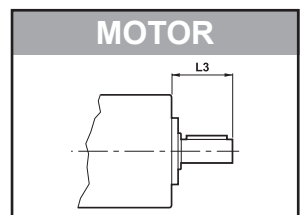

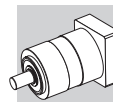

**IS**

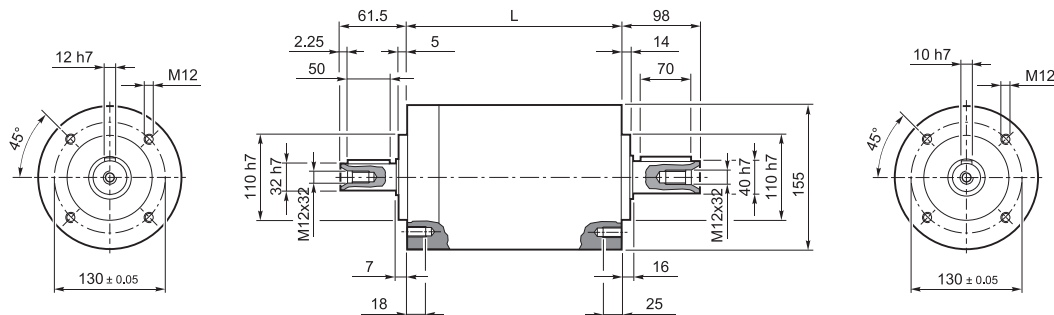

	L	
TR 160 1	155.2	17
TR 160 2	194.7	21
TR 160 3	234.2	28

**G**

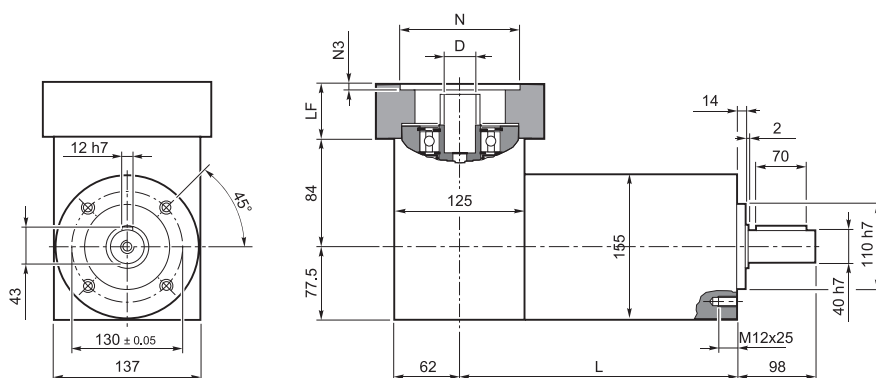

	L	
TR 160 1	218.2	24
TR 160 2	257.7	28
TR 160 3	297.2	34

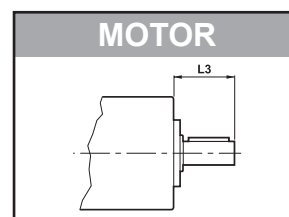

	D	N	N1	N2	N3	N4	LF	L3
TR 160_ 14...19 50 55.5 125.7	≤ 19 mm	55.5	125.7	140	5	M6x15	39.5	50
TR 160_ 14...19 50 80 100		80	100	140	5	M6x15	39.5	50
TR 160_ 14...24 50 95 115	≤ 24 mm	95	115	140	5	M8x20	39.5	50
TR 160_ 14...24 50 110 130		110	130	140	5	M8x20	39.5	50
TR 160_ 14...24 60 110 145		110	145	140	6.5	M8x20	49.5	60
TR 160_ 14...24 50 130 165	≤ 32 mm	130	165	140	5	M10x20	39.5	50
TR 160_ 14...32 60 130 165		130	165	140	5	M10x20	49.5	60
TR 160_ 14...32 60 180 215		180	215	190	5.5	M14x25	49.5	60
TR 160_ 14...38 80 114.3 200		180	215	190	6.5	M12x25	69.5	80
TR 160_ 14...38 80 180 215	≤ 38 mm	180	215	190	6.5	M14x25	69.5	80

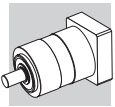

### 3.7 TR 190

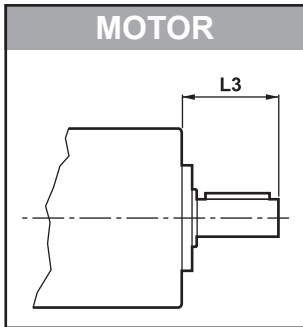
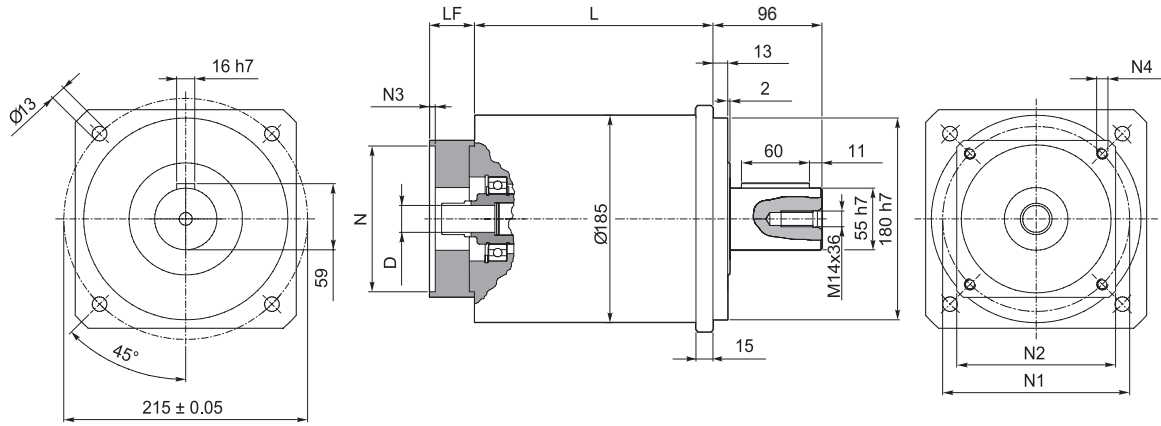

	L	kg
TR 190 1	158.7	25
TR 190 2	210.4	29
TR 190 3	262.1	34

	D	N	N1	N2	N3	N4	Lf	L3
TR 190_ 14...19 50 55.5 125.7	≤ 19 mm	55.5	125.7	140	5	M6x15	39.5	50
TR 190_ 14...19 50 80 100		80	100	140	5	M6x15	39.5	50
TR 190_ 14...24 50 95 115	≤ 24 mm	95	115	140	5	M8x20	39.5	50
TR 190_ 14...24 50 110 130		110	130	140	5	M8x20	39.5	50
TR 190_ 14...24 60 110 145		110	145	140	6.5	M8x20	49.5	60
TR 190_ 14...24 50 130 165		130	165	140	5	M10x20	39.5	50
TR 190_ 14...32 60 130 165	≤ 32 mm	130	165	140	5	M10x20	49.5	60
TR 190_ 14...32 60 180 215		180	215	190	5.5	M14x25	49.5	60
TR 190_ 14...48 80 114.3 200	≤ 48 mm	114.3	200	170	6.5	M12x25	69.5	80
TR 190_ 14...48 80 180 215		180	215	190	6.5	M14x25	69.5	80

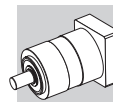

### 3.8 GETRIEBE OHNE MOTOR-VERBINDUNGSFLANSCH

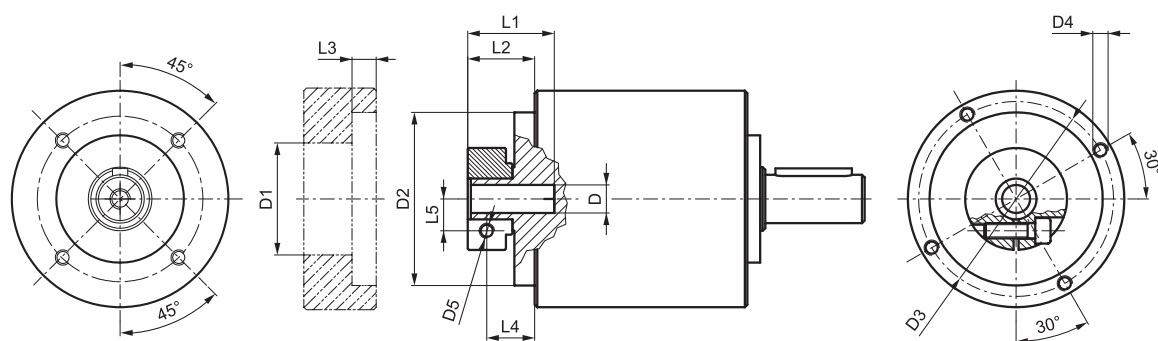

	D (F7)	D1	D2 (h7)	D3	D4	D5	L1	L2	L3 +0.1 +0.2	L4	L5
TR 053	6 -6.35 -7	32.5	50	42.5	M4x8	M4	21.7	13.2	3	8.2	8
	8 -9 -9.52 -10	32.5	50	42.5	M4x8	M4	21.7	13.2	3	8.2	9
	11 -12 -12.7	35.5	50	42.5	M4x8	M4	22	13.5	3	8.5	11
	14	35.5	50	42.5	M4x8	M4	25	17	3	10.2	11.5
TR 060	6 -6.35 -7	32.5	50	42.5	M4x8	M4	21.7	13.2	3	8.2	8
	8 -9 -9.52 -10	32.5	50	42.5	M4x8	M4	21.7	13.2	3	8.2	9
	11 -12 -12.7	35.5	50	42.5	M4x8	M4	22	13.5	3	8.5	11
	14	35.5	50	42.5	M4x8	M4	25	17	3	10.2	11.5
TR 080	8 -9 -9.52	38	68	76.5	M6x10	M6	34	26.3	9.5	18.8	10.5
	11 -12 -12.7	43	68	76.5	M6x10	M6	34	26.3	9.5	18.8	12.5
	14 -15.875 -16 -17	48	68	76.5	M6x10	M6	34	26.3	9.5	18.8	14.5
	19 -19.05	51	68	76.5	M6x10	M6	34	26.3	9.5	18.8	16.5
TR 105	11 -12 -12.7	43	90	98	M6x15	M6	33.5	20	7.6	12.5	12.5
	14 -15 -15.875 -16	48	90	98	M6x15	M6	33.5	20	7.6	12.5	14.5
	19	51	90	98	M6x15	M6	33.5	20	7.6	12.5	16.5
	22 -24	56.5	90	98	M6x15	M6	36.5	23	7.6	14	19
	28	67	90	98	M6x15	M8	36.5	23	7.6	14	22.5
TR 130	32	71	90	98	M6x15	M8	38	24.5	7.6	15.5	24.5
	14 -15.875 -16	48	113	125.5	M8x15	M6	40	27.5	6	20	14.5
	19	51	113	125.5	M8x15	M6	40	27.5	6	20	16.5
	22 -24	56.5	113	125.5	M8x15	M6	41	28.5	6	19.5	19
	28	67	113	125.5	M8x15	M8	41	28.5	6	19.5	22.5
	32	71	113	125.5	M8x15	M8	41	28.5	6	18.5	24.5
TR 160	35	73	113	125.5	M8x15	M8	50	37.5	11.25	26	26
	38	77.5	113	125.5	M8x15	M8	50	37.5	11.25	26	28
	14 -15.875 -16	48	130	142.5	M8x16	M6	40	27.5	6	20	14.5
	19	51	130	142.5	M8x16	M6	40	27.5	6	20	16.5
	22 -24	56.5	130	142.5	M8x16	M6	41	28.5	6	19.5	19
	28	67	130	142.5	M8x16	M8	41	28.5	6	19.5	22.5
TR 190	32	71	130	142.5	M8x16	M8	41	28.5	6	18.5	24.5
	35	73	130	142.5	M8x16	M8	50	37.5	11.25	26	26
	38	77.5	130	142.5	M8x16	M8	50	37.5	11.25	26	28
	14 -16	48	130	142.5	M8x14	M6	45.5	27.5	6	20	14.5
	19	51	130	142.5	M8x14	M6	45.5	27.5	6	20	16.5
	22 -24	56.5	130	142.5	M8x14	M6	47	29	6	20	19
	28	67	130	142.5	M8x14	M8	47	29	6	20	22.5
	32	71	130	142.5	M8x14	M8	47	29	6	20	24.5
TR 190	35	73	130	142.5	M8x14	M8	54.5	36.5	6	25	26
	38	77.5	130	142.5	M8x14	M8	54.5	36.5	6	25	28
	42	92	130	142.5	M8x14	M10	60.5	40	6	25	33
	45	95	130	142.5	M8x14	M10	60.5	40	6	25	33
	48	97	130	142.5	M8x14	M10	60.5	40	6	25	33

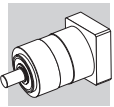

## INDEX VON NEUAUSGABEN (R)

R1	
	BESCHREIBUNG
24 ... 35	Kapitel 3 „Abmessungen - Abmessungen und Verfügbarkeit Motoranschlussflansche aktualisiert

100722

Diese Veröffentlichung annulliert und ersetzt jeder hergehende Edition oder Revision. BONFIGLIOLI behält sich das Recht vor, Änderungen ohne vorherige Informationen durchzuführen.



TR



*[www.tecnoingranaggi.it](http://www.tecnoingranaggi.it)*

## **TECNOINGRANAGGI**

TECNOINGRANAGGI RIDUTTORI s.r.l.  
Via Davia, 5  
40017 S. Giovanni in Persiceto  
Bologna (ITALY)  
Tel. (+39) 0516878111  
Fax (+39) 0516878132  
[www.tecnoingranaggi.it](http://www.tecnoingranaggi.it)  
[info@tecnoingranaggi.it](mailto:info@tecnoingranaggi.it)